

TDX[®] SC
TDX Spree
Power Wheelchair Base

DEALER: This manual **MUST** be given to the user of the wheelchair.

USER: **BEFORE** using this wheelchair, read this manual and save for future reference.

For more information regarding
Invacare products, parts, and services,
please visit www.invacare.com



Yes, you can.

WARNING

A qualified technician MUST perform the initial set up of this wheelchair. Also, a qualified technician MUST perform all procedures in the service manual.

DO NOT use this product or any available optional equipment without first completely reading and understanding these instructions and any additional instructional material such as owner’s manuals, service manuals or instruction sheets supplied with this product or optional equipment. If you are unable to understand the warnings, cautions or instructions, contact a healthcare professional, dealer or technical personnel before attempting to use this equipment - otherwise, injury or damage may occur.

ACCESSORIES WARNING

Invacare products are specifically designed and manufactured for use in conjunction with Invacare accessories. Accessories designed by other manufacturers have not been tested by Invacare and are not recommended for use with Invacare products.

REFERENCE DOCUMENTS

Refer to the table below for part numbers of additional documents which are referenced in this manual.

MANUAL	PART NUMBER
MK6i™ Electronics Programming Guide	1141471
Adjustable ASBA Owner’s Manual	1143196
Van Seat Owner’s Manual	1143195
Formula™ CG Seating System	1143155
Adjustable ASBA Service Manual	1143238

NOTE: Updated versions of this manual are available on www.invacare.com.

TABLE OF CONTENTS

REFERENCE DOCUMENTS	2
SPECIAL NOTES	7
LABEL LOCATIONS	9
All Wheelchairs and Wheelchairs with Elevate.....	9
Wheelchairs with TRRO	10
Wheelchairs without TRRO.....	10
TYPICAL PRODUCT PARAMETERS	11
SECTION 1—GENERAL GUIDELINES	12
Repair or Service Information	12
Operation Information.....	12
Wheelchairs with TRRO or TRBKTS Only.....	13
Electrical	13
Grounding Instructions.....	13
Batteries.....	14
Charging Batteries	14
Rain Test.....	14
Weight Training	14
Weight Limitation.....	14
SECTION 2—EMI INFORMATION	15
SECTION 3—SAFETY/HANDLING OF WHEELCHAIRS	17
Stability and Balance.....	17
Stability Lock.....	18
Coping with Everyday Obstacles	19
A Note to Wheelchair Assistants	19
Reaching, Leaning and Bending - Forward	20
Moving Unoccupied Wheelchairs.....	20
Reaching, Bending - Backward.....	20
Pinch Points.....	21
Stairways.....	21
Transferring To and From Other Seats	22

TABLE OF CONTENTS

SECTION 4—SAFETY INSPECTION/TROUBLESHOOTING	23
Safety Inspection Checklists.....	23
Inspect/Adjust Initially	23
Inspect/Adjust Weekly.....	24
Inspect/Adjust Monthly.....	24
Inspect/Adjust Periodically.....	25
Inspect/Adjust Every 2 Years	25
Troubleshooting - Mechanical	25
Troubleshooting - Electrical.....	26
SPJ™ +, SPJ+ w/PSS or SPJ+ w/ACC Joysticks	26
MPJ™ +, PSR+, PSF+ Joysticks or Displays.....	28
Checking Battery Charge Level.....	29
SECTION 5—WHEELCHAIR OPERATION	30
Operating the Wheelchair.....	30
Turning the Power On/Off.....	30
Using the Joystick to Drive the Wheelchair.....	31
SPJ+, MK6i SPJ+ w/PSS and MK6i SPJ+ w/ACC Joystick Switches and Indicators	32
On/Off Button	32
Speedometer.....	32
Speed Control Buttons.....	33
Joystick.....	33
Charger/Programming Input.....	33
Service Indicator.....	33
Information Gauge Display	33
MPJ+ Joystick Switches and Indicators	34
Drive Select Toggle Switch.....	34
Speed Control	34
Joystick.....	34
Charger/Programming Input.....	35
LCD Display Screens.....	35
Programmable Mono Port 1/2 or External Mode Switch.....	37
Remote On/Off Switch.....	38
Mode Switch.....	38
Memory Card Slot.....	38
Repositioning Joystick.....	39
Van Seats.....	39
Adjustable ASBA Seats.....	39
Disconnecting/Connecting the Joysticks	40
SPJ+ Joysticks	40
MPJ+ Joysticks.....	40

TABLE OF CONTENTS

SECTION 6—SEAT - TDX SC ONLY	41
Removing/Installing or Tilting the Seat Assembly	41
Removing/Installing the Seat Assembly - Wheelchairs with Latch Bars Only.....	41
Tilting the Seat Assembly - Wheelchairs without Latch Bar Only.....	42
SECTION 7—MOTOR LOCKS	44
Disengaging/Engaging Motor Lock Levers.....	44
SECTION 8—WHEEL LOCKS	45
Disengaging/Engaging the Wheel locks.....	45
Engaging.....	45
Disengaging.....	45
SECTION 9—FOOTBOARD ASSEMBLY	46
Removing/Installing the Footboard.....	46
Removing	46
Installing.....	46
Adjusting the Footboard Angle	46
SECTION 10—FORKS	47
Adjusting Forks	47
SECTION 11—WHEELS AND SHROUDS	48
Replacing the Flat Free Tires on the Wheel Rim.....	48
Removing/Installing the Top Shroud	48
Wheelchairs without Elevating Seat	48
Wheelchairs with Elevating Seat.....	49

SECTION 12—BATTERIES	50
Warnings For Handling and Replacing Batteries	50
Using the Proper Batteries.....	51
Removing/Installing the Batteries.....	51
Removing/Installing the Batteries on TDX SC without Elevating Seat.....	52
Installing/Removing the Batteries on TDX SC with Elevating Seat or TDX Spree.....	53
Installing/Removing the Batteries on TDX Spree with TRRO	55
Removing/Installing the Elevating Seat Assembly.....	57
Replacing the Batteries.....	58
Disconnecting/Connecting Battery Cables.....	58
Disconnecting Battery Cables.....	58
Connecting Battery Cables.....	59
When to Charge Batteries.....	61
SPJ+, SPJ+ w/PSS and SPJ+ w/ACC Joysticks.....	61
MPJ+ Joystick.....	61
Charging Batteries	61
Description and Use of Battery Chargers.....	62
Cleaning Battery Terminals.....	63
SECTION 13—TRANSPORT READY PACKAGE (TRRO)	64
About Transport Ready Packages.....	65
Compliance Information	65
Specifications.....	65
Securing the Wheelchair to the Vehicle	66
Positioning the Wheelchair in the Vehicle.....	66
Securement Points.....	67
Securing the Wheelchair	67
Securing the Occupant.....	68
Wheelchair-Anchored Belts.....	68
Vehicle-Anchored Belts	70
Seating System	71
Positioning Belts	71
NOTES	72
GLOBAL LIMITED WARRANTY (EXCLUDING CANADA)	74
CANADA LIMITED WARRANTY	75

SPECIAL NOTES

Signal words are used in this manual and apply to hazards or unsafe practices which could result in personal injury or property damage. Refer to the table below for definitions of the signal words.

SIGNAL WORD	MEANING
DANGER	Danger indicates an imminently hazardous situation which, if not avoided, will result in death or serious injury.
WARNING	Warning indicates a potentially hazardous situation which, if not avoided, could result in death or serious injury.
CAUTION	Caution indicates a potentially hazardous situation which, if not avoided, may result in property damage or minor injury or both.

NOTICE

THE INFORMATION CONTAINED IN THIS DOCUMENT IS SUBJECT TO CHANGE WITHOUT NOTICE.

WHEELCHAIR USER

As a manufacturer of wheelchairs, Invacare endeavors to supply a wide variety of wheelchairs to meet many needs of the end user. However, final selection of the type of wheelchair to be used by an individual rests solely with the user and his/her healthcare professional capable of making such a selection. Invacare highly recommends working with a certified rehab technology supplier and/or a member of NRRTS or RESNA.

WHEELCHAIR TIE-DOWN RESTRAINTS AND SEAT RESTRAINTS (TRRO OR TRBKTS)

TRRO includes four factory-installed transport brackets and a wheelchair anchored pelvic belt. TRRO has been crash-tested in accordance with ANSI/RESNA WC Vol I Section 19 Frontal Impact Test requirements for wheelchairs with a 130 lb crash test dummy, which corresponds to a person with a weight of 125 to 165 lbs. for Junior seat sizes or a 168 lb crash dummy, which corresponds to a person with a weight of 165 to 300 lbs. for Adult seat sizes.

TRBKTS includes four factory-installed wheelchair transport brackets. TRBKTS has not been crash-tested in accordance with WC 19. Use these transport brackets only to secure an unoccupied wheelchair during transport.

As of this date, the U.S. Department of Transportation has not approved any tie-down systems for transportation of a user while in a wheelchair, in a moving vehicle of any type. It is Invacare's position that users of wheelchairs should be transferred into appropriate seating in vehicles for transportation and use be made of the restraints made available by the auto industry. Invacare cannot and does not recommend any wheelchair transportation systems.

Refer to **Transport Ready Package (TRRO)** on page 64 for more information about transporting the wheelchair.

⚠ TRRO AND TRBKTS WARNINGS

Only use the transport brackets included with TRRO and TRBKTS for the purposes described in this manual.

Battery support brackets **MUST** be installed at all times. Otherwise, the wheelchair will not be WC/19 compliant. Refer to Removing/Installing the Batteries on page 51.

⚠ WARNING

Invacare products are specifically designed and manufactured for use in conjunction with Invacare accessories. Accessories designed by other manufacturers have not been tested by Invacare and are not recommended for use with Invacare products.

The seat positioning strap is a positioning belt **ONLY**. It is not designed for use as a safety device withstanding high stress loads such as auto or aircraft safety belts. If signs of wear appear, belt **MUST** be replaced **IMMEDIATELY**.

The drive behavior initially experienced by the user may be different from other wheelchairs previously used. This power wheelchair has Invacare's SureStep[®] technology, a feature that provides the wheelchair with optimum traction and stability when driving forward over transitions and thresholds of up to 2-3/8 inches (60mm). The following warnings apply specifically to the SureStep feature:

- **DO NOT** use on inclines greater than 9°.
- **DO NOT** use on inclines with wet, slippery, icy or oily surfaces. This may include certain painted or otherwise treated wood surfaces.
- **DO NOT** traverse down ramps at high speed. Doing so will reduce traction and increase stopping distance.
- The end user's weight can materially affect traction on sloped surfaces. Great care should be taken when traversing such slopes.

To determine and establish your particular safety limits, practice use of this product on various sloping surfaces in the presence of a qualified healthcare provider before attempting active use of this wheelchair. Other general warnings listed within this document also apply.

Wheelchairs should be examined during maintenance for signs of corrosion (water exposure, incontinence, etc.). Electrical components damaged by corrosion should be replaced **IMMEDIATELY**.

Wheelchairs that are used by incontinent users and/or are frequently exposed to water may require replacement of electrical components more frequently.

LABEL LOCATIONS

All Wheelchairs and Wheelchairs with Elevate

NOTE: 1150709 located under the top shroud

NOTE: 1079203 on wheelchairs with elevate only.

⚠ WARNING The POSITIVE (+) RED Battery Cable MUST connect to the POSITIVE (+) Battery Terminal(s)/Post(s). The NEGATIVE (-) BLACK Battery Cable MUST connect to the NEGATIVE (-) Battery Terminal(s)/Post(s). DO NOT allow Battery Cable(s) to contact the opposite Battery Terminal(s)/Post(s). Install protective caps on POSITIVE (+) and NEGATIVE (-) battery terminals. Replace cable(s) IMMEDIATELY if cable(s) insulation becomes damaged. Failure to observe these warnings may result in an electrical short with serious personal injury and/or damage to the electrical system. See Owner's Manual. DO NOT remove fuse or mounting hardware from POSITIVE (+) RED battery cable mounting screw. DO NOT REMOVE THIS LABEL.

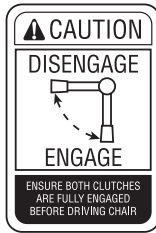

⚠ CAUTION
To avoid injury or property damage when moving an unoccupied wheelchair down an incline, perform the following:

- Engage motor lock levers.
- Turn power on and adjust speed to minimal setting.
- Drive wheelchair forward down incline.

1154313 Rev A

NO WHEELCHAIR HAS BEEN APPROVED FOR USE AS A SEATING SURFACE WITHIN A MOTOR VEHICLE. THIS LABEL IS FOR INFORMATIONAL PURPOSES ONLY. LIABILITY ISSUES WERE NOT CONSIDERED IN THE ATTACHMENT OF THIS LABEL.

AUCUN FAUTEUIL ROULANT N'A ÉTÉ APPROUVÉ POUR ÊTRE UTILISÉ COMME SIÈGE À L'INTÉRIEUR D'UN VÉHICULE MOTORISÉ. CETTE ÉTIQUETTE NE PEUT ÊTRE UTILISÉE QU'À TITRE D'INFORMATION ET N'A PAS ÉTÉ AFFICHÉE ICI POUR DES RAISONS DE RESPONSABILITÉ LÉGALE.

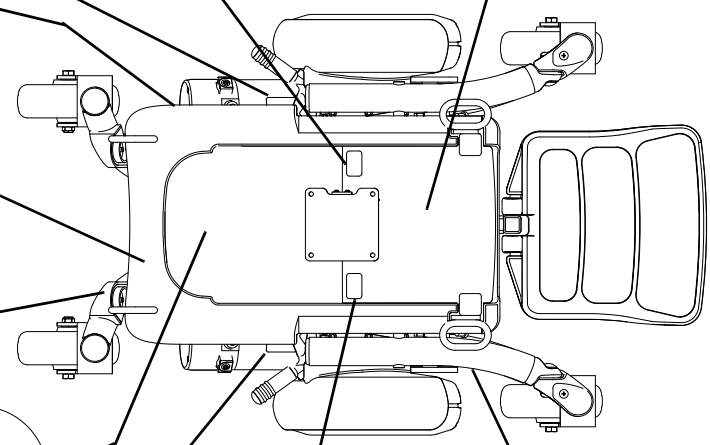
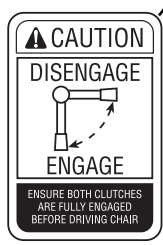

Serial Number Label

Serial Number Label

Weight Capacity Label located here

Wheelchairs with TRRO

THIS WHEELCHAIR COMPLIES WITH **ANSI/RESNA WC/19**
WARNING
 Refer to attached **TRANSPORT READY OPTION** Instruction Card and wheelchair Owner's Manual before use.
P/N 1082692 REV B - 08/05

WARNING
 Adjustments to the wheelchair may void WC/19 compliance. To maintain compliance, refer to wheelchair service manual before making any adjustments.
1134848 Rev A - 09/05

NOTE: Also on opposite side.

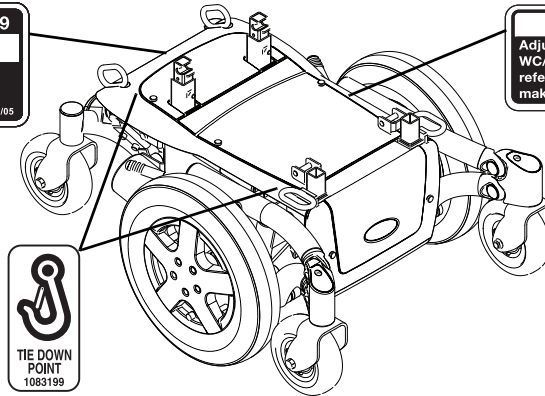

NOTE: Also on opposite side.

TIE DOWN POINT
 1083199

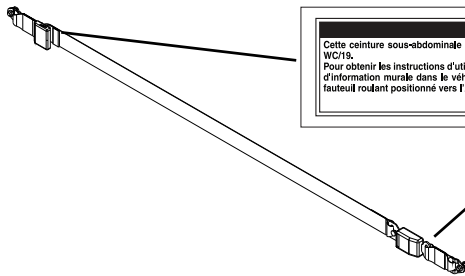

MISE EN GARDE
 Cette ceinture sous-abdominale de retenue de l'occupant est conforme à la norme ANSI/RESNA WC19.
 Pour obtenir les instructions d'utilisation, consulter le guide d'utilisateur ou s'il y a lieu la plaquette d'information murale dans le véhicule. Cette ceinture sous-abdominale doit être utilisée avec un fauteuil roulant positionné vers l'AVANT seulement.
P/N 1134840 REV B

WARNING
 This Occupant restraint/pelvic belt conforms with ANSI/RESNA WC19.
 For operating instructions, refer to owner's manual, or if equipped, wall-mounted vehicle placard. This pelvic belt is for use with wheelchair in FORWARD facing direction only.
P/N 1134840 REV B

SURE-LOK
 PELVIC BELT, TYPE 1
 FE200874-105/INV
 MXXXXXX XX/XX
CONFORMS TO APPLICABLE REQUIREMENTS OF SAE J2839, ADA, FMVSS, ISO 10543-1 AND CSA Z265.

THIS WHEELCHAIR COMPLIES WITH **ANSI/RESNA WC/19**
WARNING
 Refer to attached **TRANSPORT READY OPTION** Instruction card and wheelchair Owner's Manual before use.
 Lower seat to lowest position, ensure docking pins are fully engaged and power is turned off before placing wheelchair into vehicle, securing for transport and removing the wheelchair from vehicle.
P/N 1150756 Rev A

NOTE: 1150756 and 1150757 are on TDX Spree with TRRO only.

WARNING
 Before removing or installing the docking pin brackets, refer to the owner's manual. Otherwise serious personal injury or damage may occur.
P/N 1150757 Rev A

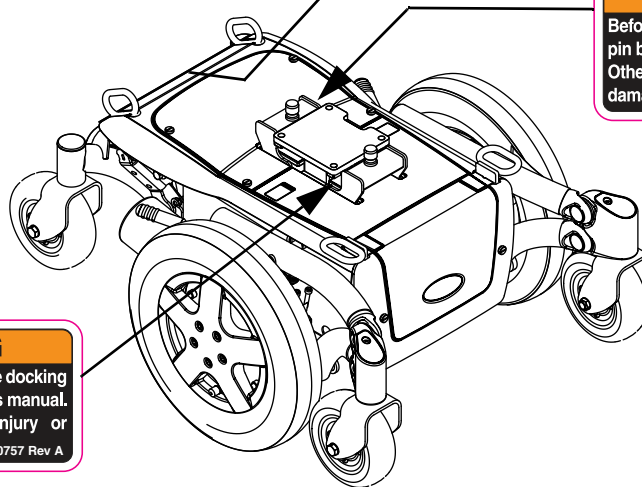

WARNING
 Before removing or installing the docking pin brackets, refer to the owner's manual. Otherwise serious personal injury or damage may occur.
P/N 1150757 Rev A

Wheelchairs without TRRO

NOTE: Auto style seat positioning strap shown. This label is also on the airline style seat positioning strap.

WARNING
 This seat/chest positioning strap is **NOT** intended for occupant restraint in a moving motor vehicle, and **DOES NOT** conform with ANSI/RESNA WC/19. If signs of wear appear, positioning strap **MUST** be replaced **IMMEDIATELY**.



TYPICAL PRODUCT PARAMETERS

	TDX SC	TDX SPREE
BASE LENGTH:	34 inches without Front Riggings	
OVERALL WIDTH OF BASE: WITH TWO UI BATTERIES:	24 inches without joystick	
OVERALL HEIGHT WITH ASBA SEAT: WITH VAN SEAT:	36.5 to 38.5 inches 38 inches (without head rest), 45 inches (with head rest)	34.5 to 38.5 inches
WITH FORMULA CG TILT ONLY: WITH ELEVATING ASBA SEAT:	37.75 to 39.25 inches 36.75 to 41.75 inches	36.75 to 38.75 inches 34.5 to 38.5 inches
OVERALL LENGTH WITH CENTER MOUNT FRONT RIGGING: WITHOUT FRONT RIGGINGS:	39 inches 34 inches	
WEIGHT (BASE ONLY) WITHOUT UI BATTERIES: WITH TWO UI BATTERIES:	178 lbs 225 lbs	183 230
MOTOR:	2 Pole	
DRIVE AXLE:	Non-adjustable	
DRIVE WHEELS/TIRES:	10 x 3-inch Foam Filled	
CASTERS:	6 x 2-inch, Semi-pneumatic with Precision Sealed Bearings	
CASTER FORKS:	Two side fork (Standard), One sided fork (Optional)	
BATTERY REQUIREMENTS:	UI	
FOOTRESTS:	Telescoping Front Rigging Supports, 2-inch and 4-inch long Pivot Slide Tube	
SEAT TILT ANGLE ADJUSTMENT:	Adjustable (0° to 10°)	
*WEIGHT LIMITATION:	Up to 250 lbs	Up to 165 lbs
<p><i>NOTE: All dimensions are ±.50 inches unless otherwise indicated.</i></p> <p><i>*NOTE: Weight limitation is total weight (user weight plus any additional items that the user may require [back pack, etc.]). Example: If weight limitation of the wheelchair is 300 lbs and additional items equal 25 lbs, subtract 25 lbs from 300 lbs. This means the maximum weight limitation of the user is 275 lbs.</i></p>		

SECTION I—GENERAL GUIDELINES

WARNING

SECTION I - GENERAL GUIDELINES contains important information for the safe operation and use of this product.

Repair or Service Information

Set-up of the Electronics Control Unit is to be performed only by a qualified technician. The final adjustments of the controller may affect other activities of the wheelchair. Damage to the equipment could occur if improperly set-up or adjusted.

Except for programming, **DO NOT** service or adjust the wheelchair while occupied, unless otherwise noted. A pinch point exists between head tube cap and walking beam.

A pinch point exists between walking beam/head tube cap and telescoping tube when TDX is at the lowest seat to floor height.

Before adjusting, repairing or servicing the wheelchair, **ALWAYS** turn the wheelchair power Off, otherwise, injury or damage may occur.

Invacare products are specifically designed and manufactured for use in conjunction with Invacare accessories. Accessories designed by other manufacturers have not been tested by Invacare and are not recommended for use with Invacare products.

Transport ready packages are not retrofittable to existing models and are not field serviceable.

Wheelchairs should be examined during maintenance for signs of corrosion (water exposure, incontinence, etc.). Electrical components damaged by corrosion should be replaced **IMMEDIATELY**.

Wheelchairs that are used by incontinent users and/or are frequently exposed to water may require replacement of electrical components more frequently.

For optimum performance, replace gas-locking cylinders every 2 years.

Operation Information

Performance adjustments should only be made by professionals of the healthcare field or persons fully conversant with this process and the driver's capabilities. Incorrect settings could cause injury to the driver, bystanders, damage to the wheelchair and to surrounding property.

After the wheelchair has been set-up/adjusted, check to make sure that the wheelchair performs to the specifications entered during the set-up procedure. If the wheelchair does **NOT** perform to specifications, turn the wheelchair Off immediately and reenter set-up specifications. Repeat this procedure until the wheelchair performs to specifications.

DO NOT leave the power button On when entering or exiting your wheelchair.

DO NOT attempt to drive over curbs or obstacles greater than 2-3/8 inches (60mm). Doing so may cause your wheelchair to turn over and cause bodily harm or damage to the wheelchair. **ALWAYS** stop before climbing an obstacle. Approach slowly until casters contact the obstacle. Apply power and the action of the SureStep feature will lift the casters over the obstacle. Weight is transferred to the drive wheels providing traction and motor strength to power the wheelchair over the obstacle.

DO NOT operate on roads, streets or highways.

DO NOT climb, go up or down ramps or traverse slopes greater than 9°.

DO NOT attempt to move up or down an incline with water, ice or oil film.

DO NOT stand on the frame of the wheelchair.

DO determine and establish your particular safety limits by practicing bending, reaching and transferring activities in the presence of a qualified healthcare professional before attempting active use of the wheelchair.

DO NOT attempt to reach objects if you have to move forward in your seat.

DO NOT attempt to reach objects if you have to pick them up from the floor by reaching between your knees.

DO NOT lean over the top of the back upholstery to reach objects behind you, as this may cause the wheelchair to tip over.

ALWAYS shift your weight in the direction you are turning. **DO NOT** shift your weight in the opposite direction of the turn. Shifting your weight in the opposite direction of the turn may cause the inside drive wheel to lose traction and the wheelchair to tip over.

DO NOT shift your weight or sitting position toward the direction you are reaching as the wheelchair and/or seating system (if any) may tip over.

DO NOT use an escalator to move a wheelchair between floors. Serious bodily injury may occur.

DO NOT use the footplates as a platform. When getting in or out of the wheelchair, make sure that the footplates are in the upward position or swing footrests towards the outside of the wheelchair.

If the wheelchair dips forward and the footplates touch the ground while the wheelchair is in motion, please contact dealer for an inspection and avoid use of the wheelchair if possible. Otherwise the user could be injured.

While the wheelchair is moving, minimum ground clearance for the front rigging is three inches. If the wheelchair is not moving, the front rigging **MUST** maintain a minimum of one inch ground clearance - otherwise personal injury and damage may result.

NEVER leave an unoccupied wheelchair unattended on an incline.

DO NOT attempt to stop a moving wheelchair with the wheel locks. Wheel locks are not brakes.

DO NOT attempt to lift the wheelchair by any removable (detachable) parts. Lifting by means of any removable (detachable) parts of the wheelchair may result in injury to the user or damage to the wheelchair.

DO NOT overtighten hardware attaching to the frame. This could cause damage to the frame tubing.

ALWAYS keep hands and fingers clear of moving parts to avoid injury.

ALWAYS wear your seat positioning strap. The seat positioning strap is a positioning belt **ONLY**. It is not designed for use as a safety device withstanding high stress loads such as auto or aircraft safety belts. If signs of wear appear, belt **MUST** be replaced immediately.

ALWAYS turn the wheelchair power off and engage the motor locks/clutches to prevent the wheels from moving before attempting to transfer in or out of the wheelchair. Also make sure every precaution is taken to reduce the gap distance. Align both casters parallel with the object you are transferring onto.

DO NOT use with a broken or missing joystick knob.

DO NOT use if joystick does not spring back to the neutral position or becomes sticky or sluggish.

DO NOT use if joystick boot is torn or damaged.

ALWAYS check foam grips for looseness before using the wheelchair. If loose, contact a qualified technician for instructions.

ALWAYS engage both wheel locks and reduce the gap distance before transferring to and from the wheelchair. Turn all casters parallel to the object you are transferring onto.

Avoid storing or using the wheelchair near open flame or combustible products. Serious injury or damage to property may result.

DO NOT engage or disengage the motor locks until the power is in the off position.

Wheelchairs with TRRO or TRBKTS Only

Only use the transport brackets included with TRRO and TRBKTS for the purposes described in this manual.

Electrical

Grounding Instructions

DO NOT, under any circumstances, cut or remove the round grounding prong from any plug used with or for Invacare products. Some devices are equipped with three-prong (grounding) plugs for protection against possible shock hazards. Where a two-prong wall receptacle is encountered, it is the personal responsibility and obligation of the customer to contact a qualified electrician and have the two-prong receptacle replaced with a properly grounded three-prong wall receptacle in accordance with the National Electrical Code. If you must use an extension cord, use only a three-wire extension cord having the same or higher electrical rating as the device being connected. In addition, Invacare has placed RED/ORANGE warning tags on some equipment. DO NOT remove these tags.

Batteries

The warranty and performance specifications contained in this manual are based on the use of AGM batteries. Invacare strongly recommends their use as the power source for this unit.

Carefully read battery/battery charger information prior to installing, servicing or operating your wheelchair.

Charging Batteries

DANGER

When using an extension cord, use only a three wire extension cord having at least 16 AWG (American Wire Gauge) wire and the same or higher electrical rating as the device being connected. Use of improper extension cord could result in risk of fire and electric shock. Three prong to two prong adapters should not be used. Use of three prong adapters can result in improper grounding and present a shock hazard to the user.

NEVER attempt to recharge the batteries by attaching cables directly to the battery terminals.

DO NOT attempt to recharge the batteries and operate the wheelchair at the same time.

DO NOT operate wheelchair with extension cord attached to the AC cable.

DO NOT attempt to recharge the batteries when the wheelchair has been exposed to any type of moisture.

DO NOT attempt to recharge the batteries when the wheelchair is outside.

DO NOT sit in the wheelchair while charging the batteries.

READ and CAREFULLY follow the manufacturer's instructions for each charger (supplied or purchased). If charging instructions are not supplied, consult a qualified technician for proper procedures.

Ensure the pins of the extension cord plug are the same number, size, and shape as those on the charger.

DO NOT under any circumstances cut or remove the round grounding plug from the charger AC cable plug or the extension cord plug.

Rain Test

Invacare has tested its power wheelchairs in accordance with ISO 7176 "Rain Test". This provides the end user or his/her attendant sufficient time to remove his/her power wheelchair from a rain storm and retain wheelchair operation.

DO NOT leave power wheelchair in a rain storm of any kind.

DO NOT use power wheelchair in a shower.

DO NOT leave power wheelchair in a damp area for any length of time.

Direct exposure to rain or dampness will cause the wheelchair to malfunction electrically and mechanically; may cause the wheelchair to prematurely rust or may damage the upholstery.

Check to ensure that the battery covers are secured in place, joystick boot is NOT torn or cracked where water can enter and that all electrical connections are secure at all times.

DO NOT use if the joystick boot is torn or cracked. If the joystick boot becomes torn or cracked, replace IMMEDIATELY.

Weight Training

Invacare DOES NOT recommend the use of its wheelchairs as a weight training apparatus. Invacare wheelchairs have NOT been designed or tested as a seat for any kind of weight training. If occupant uses said wheelchair as a weight training apparatus, INVACARE SHALL NOT BE LIABLE FOR BODILY INJURY AND THE WARRANTY IS VOID.

Weight Limitation

Refer to Typical Product Parameters for [Typical Product Parameters](#) on page 11 to determine the weight limit (total combined weight of user and any attachments) of your wheelchair model. DO NOT exceed the limit - otherwise, injury or damage may result.

SECTION 2—EMI INFORMATION

⚠ WARNING

CAUTION: IT IS VERY IMPORTANT THAT YOU READ THIS INFORMATION REGARDING THE POSSIBLE EFFECTS OF ELECTROMAGNETIC INTERFERENCE ON YOUR POWERED WHEELCHAIR.

Electromagnetic Interference (EMI) From Radio Wave Sources

Powered wheelchairs and motorized scooters (in this text, both will be referred to as powered wheelchairs) may be susceptible to electromagnetic interference (EMI), which is interfering electromagnetic energy (EM) emitted from sources such as radio stations, TV stations, amateur radio (HAM) transmitters, two way radios, and cellular phones. The interference (from radio wave sources) can cause the powered wheelchair to release its brakes, move by itself, or move in unintended directions. It can also permanently damage the powered wheelchair's control system. The intensity of the interfering EM energy can be measured in volts per metre (V/m). Each powered wheelchair can resist EMI up to a certain intensity. This is called its "immunity level." The higher the immunity level, the greater the protection. At this time, current technology is capable of achieving at least a 20 V/m immunity level, which would provide useful protection from the more common sources of radiated EMI.

There are a number of sources of relatively intense electromagnetic fields in the everyday environment. Some of these sources are obvious and easy to avoid. Others are not apparent and exposure is unavoidable. However, we believe that by following the warnings listed below, your risk to EMI will be minimized.

The sources of radiated EMI can be broadly classified into three types:

- 1) Hand-held Portable transceivers (transmitters-receivers with the antenna mounted directly on the transmitting unit. Examples include: citizens band (CB) radios, "walkie talkie", security, fire and police transceivers, cellular telephones, and other personal communication devices).

NOTE: Some cellular telephones and similar devices transmit signals while they are ON, even when not being used.

- 2) Medium-range mobile transceivers, such as those used in police cars, fire trucks, ambulances and taxis. These usually have the antenna mounted on the outside of the vehicle; and
- 3) Long-range transmitters and transceivers, such as commercial broadcast transmitters (radio and TV broadcast antenna towers) and amateur (HAM) radios.

NOTE: Other types of hand-held devices, such as cordless phones, laptop computers, AM/FM radios, TV sets, CD players, cassette players, and small appliances, such as electric shavers and hair dryers, so far as we know, are not likely to cause EMI problems to your powered wheelchair.

⚠ WARNING**Powered Wheelchair Electromagnetic Interference (EMI)**

Because EM energy rapidly becomes more intense as one moves closer to the transmitting antenna (source), the EM fields from hand-held radio wave sources (transceivers) are of special concern. It is possible to unintentionally bring high levels of EM energy very close to the powered wheelchair's control system while using these devices. This can affect powered wheelchair movement and braking. Therefore, the warnings listed below are recommended to prevent possible interference with the control system of the powered wheelchair.

Electromagnetic interference (EMI) from sources such as radio and TV stations, amateur radio (HAM) transmitters, two-way radios, and cellular phones can affect powered wheelchairs and motorized scooters. Also, the electronics used in our powered wheelchair can generate a low level of electromagnetic interference, which however will remain within the tolerances permitted by law.

FOLLOWING THE WARNINGS LISTED BELOW SHOULD REDUCE THE CHANCE OF UNINTENDED BRAKE RELEASE OR POWERED WHEELCHAIR MOVEMENT WHICH COULD RESULT IN SERIOUS INJURY.

- 1) Do not operate hand-held transceivers (transmitters receivers), such as citizens band (CB) radios, or turn ON personal communication devices, such as cellular phones, while the powered wheelchair is turned ON;
- 2) Be aware of nearby transmitters, such as radio or TV stations, and try to avoid coming close to them;
- 3) If unintended movement or brake release occurs, turn the powered wheelchair OFF as soon as it is safe;
- 4) Be aware that adding accessories or components, or modifying the powered wheelchair, may make it more susceptible to EMI (NOTE: There is no easy way to evaluate their effect on the overall immunity of the powered wheelchair); and
- 5) Report all incidents of unintended movement or brake release to the powered wheelchair manufacturer, and note whether there is a source of EMI nearby.

Important Information

- 1) 20 volts per metre (V/m) is a generally achievable and useful immunity level against EMI (as of May 1994) (the higher the level, the greater the protection);
- 2) This device has been tested to a radiated immunity level of 20 volts per meter.
- 3) The immunity level of the product is unknown.

Modification of any kind to the electronics of this wheelchair as manufactured by Invacare may adversely affect the EMI immunity levels.

SECTION 3—SAFETY/HANDLING OF WHEELCHAIRS

“Safety and Handling” of the wheelchair requires the close attention of the wheelchair user as well as the assistant. This manual points out the most common procedures and techniques involved in the safe operation and maintenance of the wheelchair. It is important to practice and master these safe techniques until you are comfortable in maneuvering around the frequently encountered architectural barriers.

Use this information only as a “basic” guide. The techniques that are discussed on the following pages have been used successfully by many.

Individual wheelchair users often develop skills to deal with daily living activities that may differ from those described in this manual. Invacare recognizes and encourages each individual to try what works best for him/her in overcoming architectural obstacles that they may encounter, however all warnings and cautions given in this manual **MUST** be followed. Techniques in this manual are a starting point for the new wheelchair user and assistant with “safety” as the most important consideration for all.

Stability and Balance

WARNING

ALWAYS wear your seat positioning strap. The seat positioning strap is a positioning belt **ONLY**. It is not designed for use as a safety device withstanding high stress loads such as auto or aircraft safety belts. If signs of wear appear, belt **MUST** be replaced immediately.

DO NOT climb, go **UP** or **DOWN** ramps or traverse slopes greater than 9°.

Invacare strongly recommends proceeding down ramps or slopes slowly to avoid hard braking or sudden stops.

DO NOT leave elevating legrests in the fully extended position when proceeding down ramps or slopes.

Be aware that carrying heavy objects on your lap while occupying the wheelchair may adversely affect the stability of the wheelchair, resulting in serious bodily injury to the user, damage to the wheelchair and surrounding property.

This wheelchair has been designed to accommodate one individual. If more than one individual occupies the wheelchair this may adversely affect the stability of the wheelchair, resulting in serious bodily injury to the user and passenger and damage to the wheelchair and surrounding property.

⚠ WARNING

DO NOT attempt to reach objects if you have to move forward in the seat or pick them up from the floor by reaching down between your knees.

Many activities require the wheelchair user to reach, bend and transfer in and out of the wheelchair. These movements will cause a change to the normal balance, center of gravity, and weight distribution of the wheelchair. To determine and establish your particular safety limits, practice bending, reaching and transferring activities in several combinations in the presence of a qualified healthcare professional before attempting active use of the wheelchair.

Proper positioning is essential for your safety. When reaching, leaning, bending or bending forward, it is important to use the casters as a tool to maintain stability and balance.

To assure stability and proper operation of your wheelchair, you must at all times maintain proper balance. Your wheelchair has been designed to remain upright and stable during normal daily activities as long as you DO NOT move beyond the center of gravity. DO NOT lean forward out of the wheelchair any further than the length of the armrests. Make sure the casters are pointing in the forward position whenever you lean forward. This can be achieved by advancing the wheelchair and then reversing it in a straight line.

Stability Lock

⚠ WARNING

If the wheelchair dips forward and the footplates touch the ground while the wheelchair is in motion, please contact dealer for an inspection and avoid use of the wheelchair if possible. Otherwise the user could be injured.

While the wheelchair is moving, minimum ground clearance for the front rigging is three inches. If the wheelchair is not moving, the front rigging **MUST** maintain a minimum of one inch ground clearance - otherwise personal injury and damage may result.

The stability lock feature is designed to operate and keep the wheelchair stable when in motion. The stability lock is not designed to operate while the wheelchair is at rest, such as during transfers in and out of the wheelchair. DO NOT assume that the stability lock feature is operating when the wheelchair is not moving.

Coping with Everyday Obstacles

NOTE: For this procedure, refer to FIGURE 3.1

Coping with the irritation of everyday obstacles can be somewhat alleviated by learning how to manage your wheelchair. Keep in mind your center of gravity to maintain stability and balance.

While the walking beam allows you to traverse up to a 2-3/8-inch (60mm) bump or threshold, stopping after the wheels cross the bump poses a problem. The wheelchair cannot reverse over the bump at this point. Continue forward and then turn around.

While the TDX is designed for use primarily in and around the home, the provider should determine whether this wheelchair is suitable for the actual environment in which the wheelchair will be used.

NOTE: DO NOT go down a ramp at full speed. Some seat/back positions will cause the wheelchair to feel unstable.

CAUTION

Be aware of the condition of the ramp. Traction will be diminished/nonexistent on a slippery surface. Proceed with caution.

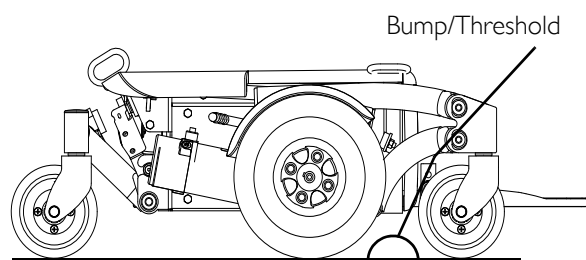

FIGURE 3.1 Coping with Everyday Obstacles

A Note to Wheelchair Assistants

When assistance to the wheelchair user is required, remember to use good body mechanics. Keep your back straight and bend your knees whenever tilting wheelchair or traversing curbs or other impediments.

Also, be aware of detachable parts such as arms or legrests. These must NEVER be used to move the wheelchair or as lifting supports, as they may be inadvertently released, resulting in possible injury to the user and/or assistant(s).

When learning a new assistance technique, have an experienced assistant help you before attempting it alone.

Reaching, Leaning and Bending - Forward

⚠ WARNING

DO NOT attempt to reach objects if you have to move forward in the seat or pick them up from the floor by reaching down between your knees.

NOTE: For this procedure, refer to FIGURE 3.2.

Position the casters so that they are extended away from the drive wheels and engage wheel locks/motor locks/clutches.

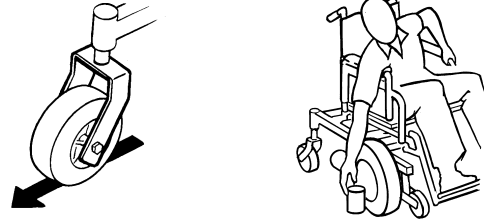

FIGURE 3.2 Reaching, Leaning and Bending - Forward

Moving Unoccupied Wheelchairs

CAUTION

To avoid injury or property damage when moving an unoccupied wheelchair down an incline, perform the following:

- Engage motor lock levers.
 - Turn power on and adjust speed to minimal setting.
 - Drive wheelchair forward down incline.
-

Reaching, Bending - Backward

⚠ WARNING

DO NOT lean over the top of the back upholstery. This will change your center of gravity and may cause you to tip over.

NOTE: For this procedure, refer to FIGURE 3.3.

Position wheelchair as close as possible to the desired object. Position the casters so that they are extended away from the drive wheels to create the longest possible wheelbase. Reach back only as far as your arm will extend without changing your sitting position.



FIGURE 3.3 Reaching, Bending - Backward

Pinch Points

⚠ WARNING

A pinch point exists between head tube cap and walking beam (Detail “A”).

A pinch point exists between walking beam/head tube cap and telescoping tube when wheelchair is at the lowest seat to floor height (Detail “B”).

Pinch point may occur when rotating the footboard assembly (Detail “C”).

NOTE: For this procedure, refer to FIGURE 3.4.

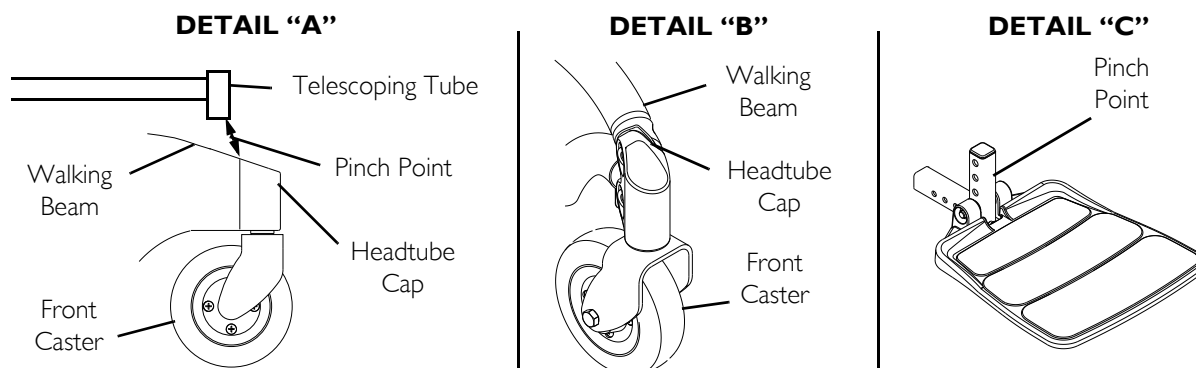

FIGURE 3.4 Pinch Points

Stairways

⚠ WARNING

DO NOT attempt to move an occupied power wheelchair between floors using a stairway. Use an elevator to move an occupied power wheelchair between floors. If moving a power wheelchair between floors by means of a stairway, the occupant **MUST** be removed and transported independently of the power wheelchair.

Extreme caution is advised when it is necessary to move an unoccupied power wheelchair up or down the stairs. Invacare recommends using two assistants and making thorough preparations. Make sure to use **ONLY** secure, non-detachable parts for hand-hold supports.

DO NOT attempt to lift the wheelchair by any removable (detachable) parts. Lifting by means of any removable (detachable) parts of a wheelchair may result in injury to the user or damage to the wheelchair.

The weight of the wheelchair without the user and without batteries is between 178 and 230 lbs. Use proper lifting techniques (lift with your legs) to avoid injury.

Follow this procedure for moving the wheelchair between floors when an elevator is NOT available:

NOTE: When using a stairway to move the wheelchair and any accessories, move all wheelchair components away from the stairway prior to reassembly.

1. Remove the occupant from the wheelchair.
2. Remove the batteries from wheelchair. Refer to [Batteries](#) on page 50.
3. Bend your knees and keep your back straight.
4. Using non-removable (non-detachable) parts of the wheelchair, lift the wheelchair off of the ground and transfer the wheelchair up or down the stairs.
5. The wheelchair should not be lowered until the last stair has been negotiated and the wheelchair has been carried away from the stairway.

⚠ WARNING: ESCALATORS

DO NOT use an escalator to move a wheelchair between floors. Serious bodily injury may occur.

Transferring To and From Other Seats

⚠ WARNING

ALWAYS turn the wheelchair power **OFF** and engage the motor locks/clutches to prevent the wheels from moving before attempting to transfer in or out of the wheelchair. Also make sure every precaution is taken to reduce the gap distance. **Align both casters parallel with the object you are transferring onto.**

CAUTION

When transferring, position yourself as far back as possible in the seat. This will prevent broken screws, damaged upholstery and the possibility of the wheelchair tipping forward.

NOTE: For this procedure, refer to FIGURE 3.5.

NOTE: Adequate mobility and upper body strength is required to perform this activity independently.

1. Position the wheelchair as close as possible along side the seat to which you are transferring, with the casters aligned parallel with the object.
2. Engage motor locks. Refer to [Disengaging/Engaging Motor Lock Levers](#) on page 44.
3. Shift body weight into seat with transfer.

NOTE: During independent transfer, little or no seat platform will be beneath you. Use a transfer board if at all possible.

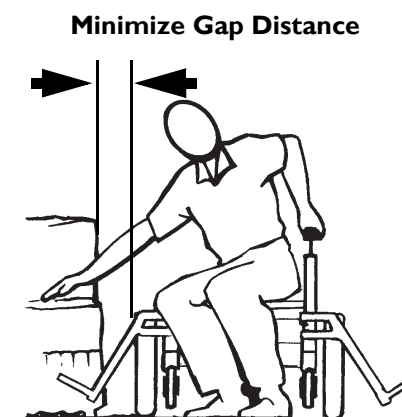

FIGURE 3.5 Transferring To and From Other Seats

SECTION 4—SAFETY INSPECTION/ TROUBLESHOOTING

NOTE: Every six months take your wheelchair to a qualified technician for a thorough inspection and servicing. Regular cleaning will reveal loose or worn parts and enhance the smooth operation of your wheelchair. To operate properly and safely, your wheelchair must be cared for just like any other vehicle. Routine maintenance will extend the life and efficiency of your wheelchair.

Initial adjustments should be made to suit your personal body structure needs and preference. Thereafter follow these maintenance procedures:

Safety Inspection Checklists

Inspect/Adjust Initially

CAUTION

As with any vehicle, the wheels and tires should be checked periodically for cracks and wear, and should be replaced.

- Ensure wheelchair rolls straight (no excessive drag or pull to one side).
- Inspect all fasteners.
- Inspect TRRO/TRBKTS fasteners and hardware.
- Ensure clothing guards are secure.
- Ensure arms are secure but easy to release and adjustment levers engage properly.
- Ensure adjustable height arms operate and lock securely.
- Ensure arm pivot points are free of wear and looseness.
- Clean upholstery and armrests.
- Inspect upholstery for rips or sagging.
- Ensure armrest pad sits flush against arm tube.
- Ensure seat release latch is functional. Replace if necessary.
- Ensure axle nut and wheel mounting nuts are secure on drive wheels.
- No excessive side movement or binding when drive wheels are lifted and spun when disengaged (free-wheeling).
- Ensure that casters are free of debris.
- Ensure wheels/casters have proper tension when wheels/casters are spun (when free-wheeling). Wheels/casters should come to a gradual stop.
- Loosen/tighten caster locknut if wheel wobbles noticeably or binds to a stop.
- Ensure all caster/wheel/fork/headtube fasteners are secure and not damaged/missing.
- Ensure wheel locks DO NOT interfere with tires when rolling.
- Ensure wheel lock pivot points are free of wear and looseness.
- Ensure wheel locks are easy to engage.
- Inspect tires for flat spots and wear.
- Check center mount front riggings for worn/frayed belts and/or loose fasteners. If found, replace these items.
- Check that all labels are present and legible. Replace if necessary.
- Inspect locking gas cylinders.
- Inspect stability lock function.

- Check that cables are routed and secured properly to ensure that cables DO NOT become entangled and damaged during normal operation of seating system.

Inspect/Adjust Weekly

CAUTION

As with any vehicle, the wheels and tires should be checked periodically for cracks and wear, and should be replaced.

- Ensure wheels/casters have proper tension when wheels/casters are spun (when free-wheeling). Wheels/casters should come to a gradual stop.
- Ensure that casters are free of debris.
- Ensure arm pivot points are free of wear and looseness.
- Ensure all caster/wheel/fork/headtube fasteners are secure and not damaged/missing.
- Loosen/tighten caster locknut if wheel wobbles noticeably or binds to a stop.
- Inspect tires for flat spots and wear.
- Ensure wheel locks DO NOT interfere with tires when rolling.
- Ensure wheel lock pivot points are free of wear and looseness.
- Ensure wheel locks are easy to engage.
- Inspect all fasteners.
- Inspect TRRO/TRBKTS fasteners and hardware.
- Check that cables are routed and secured properly to ensure that cables do NOT become entangled and damaged during normal operation of seating system.

Inspect/Adjust Monthly

- Ensure axle nut and wheel mounting nuts are secure on drive wheels.
- Clean upholstery and armrests.
- Clean dirt and lint from axles.
- Clean dirt and lint from bearings.
- Ensure that casters are free of debris.
- Inspect locking gas cylinders.
- Inspect stability lock function.
- Inspect seat positioning strap for any signs of wear. Ensure buckle latches. Verify hardware that attaches strap to frame is secure and undamaged. Replace if necessary.

Inspect/Adjust Periodically

- Ensure wheelchair rolls straight (no excessive drag or pull to one side).
- Inspect all fasteners.
- Inspect TRRO/TRBKTS fasteners and hardware.
- Ensure clothing guards are secure.
- Ensure arms are secure but easy to release and adjustment levers engage properly.
- Ensure adjustable height arms operate and lock securely.
- Inspect upholstery for rips or sagging.
- Ensure armrest pad sits flush against arm tube.
- Ensure axle nut and wheel mounting nuts are secure on drive wheels.
- Ensure wheels/casters have proper tension when wheels/casters are spun (when free-wheeling). Wheels/casters should come to a gradual stop.
- Ensure that casters are free of debris.
- Inspect foam handgrips for damage. If damaged, have them replaced by a qualified technician.
- Check center mount front riggings for worn/frayed belts and/or loose fasteners. If found, replace these items.
- Check that all labels are present and legible. Replace if necessary.
- Inspect electrical components for signs of corrosion. Replace if corroded or damaged.

Inspect/Adjust Every 2 Years

- For optimum performance, replace gas-locking cylinders.

Troubleshooting - Mechanical

WHEELCHAIR VEERS LEFT/RIGHT	SLUGGISH TURN/ PERFORMANCE	CASTERS FLUTTER	SQUEAKS AND RATTLES	LOOSENESS IN WHEELCHAIR	WHEELCHAIR 3 WHEELS	SOLUTIONS
X	X	X				If pneumatic, check tires for correct and equal pressure.
X	X	X	X			Check for loose stem nuts/bolts.
X		X				Check that casters contact ground at the same time.
				X	X	If pneumatic, check tires for correct and equal pressure.







Troubleshooting - Electrical

NOTE: For additional troubleshooting information and explanation of error codes, refer to the individual Electronics Manual supplied with each wheelchair.

SPJ™ +, SPJ+ w/PSS or SPJ+ w/ACC Joysticks

The joystick information gauge and the service indicator give indications of the type of fault or error detected by the control module. When a fault is detected, the wheelchair may stop and not drive. The LEDs on the information gauge may flash in a particular pattern or the service indicator light will flash. The number or type of flashes indicates the nature of the error. If multiple errors are found, only the first error encountered by the control module will be displayed.













Information Gauge Display Diagnostics

 DISPLAY	DESCRIPTION	DEFINITION	COMMENTS
	All LEDs are off.	Power is off.	
	All LEDs are on.	Power is on.	Fewer than three LEDs on implies reduced battery charge.
	Left RED LED is flashing.	Battery charge is low.	The batteries should be charged as soon as possible.
	Left to Right "chase" alternating with steady display.	Joystick is in programming, inhibit and/or charging mode.	The steady LEDs indicate the current state of the battery charge.
	All LEDs are flashing slowly.	Joystick has detected Out-of-Neutral-at-Power-Up mode.	Release the joystick back to Neutral.

Service Indicator Light Diagnostics

NUMBER OF FLASHES	ERROR CODE DESCRIPTION	POSSIBLE SOLUTION
1	User Fault	Release joystick to neutral and try again.
2	Battery Fault	Charge the batteries. Refer to <u>Charging Batteries</u> on page 61. Check that battery cables are connected properly. If necessary, replace batteries. Refer to <u>Replacing the Batteries</u> on page 58.
3	Left Motor Fault	Contact Invacare/Dealer for service.
4	Right Motor Fault	Contact Invacare/Dealer for service.
5	Left Park Brake Fault	Contact Invacare/Dealer for service.
6	Right Park Brake Fault	Contact Invacare/Dealer for service.
7	Remote Fault	Check to make sure joystick is connected properly. Contact Invacare/Dealer for service.
8	Controller Fault	Contact Invacare/Dealer for service.
9	Communications Fault	Contact Invacare/Dealer for service.
10	General Fault	Contact Invacare/Dealer for service.
11	Incompatible or incorrect Remote	Wrong type of remote connected. Contact Invacare/Dealer for service.

MPJ™ +, PSR+, PSF+ Joysticks or Displays

SYMPTOM	PROBABLE CAUSE	SOLUTIONS
 SPM L Park Brake Fault or  SPM R Park Brake Fault displays and wheelchair does not drive.	Motor, Controller or other electrical device (Error code E9 or E10).	Contact Dealer/Invacare for service.
CHARGER PLUGGED IN displays.	Battery charger connected (Error code E28).	Unplug battery charger from the wheelchair. Refer to Charging Batteries on page 61.
 SPM Battery Fault displays and the wheelchair does not drive.	Batteries need to be charged (Error code E14).	Charge batteries. Refer to Charging Batteries on page 61. If batteries fail to charge properly, check battery charger or replace batteries. Refer to Replacing the Batteries on page 58.
 JOYSTICK TIMEOUT displays and the wheelchair does not drive.	Joystick or input device is disconnected (Error code 32).	Turn off power, reconnect the joystick of input device and turn power on.
 JS REV TOO LARGE  JS FWD TOO LARGE  JS LFT TOO LARGE or  JS RGT TOO LARGE displays and the wheelchair does not drive.	The joystick or input device is sending a value outside of the reverse, forward, left or right limits (Error codes E01, E02, E03 or E04).	Replace joystick or input device.
NEUTRAL TESTING displays.	The joystick neutral test has failed (Error code E18).	Release the joystick and try to get the joystick back into the center-most position.
 BAD JOYSTICK CAL VALUES displays and the wheelchair does not drive.	The joystick calibration values are outside of the expected range (Error code E19).	Recalibrate the joystick (joystick throw procedure).
 SPM NOT CONNECTED	The MPJ or Display module is not communicating with the control module (Error code E200).	Check the connections between the joystick or display and the controller. Turn the power off and then back on. Replace the controller if necessary.
 SPM Communications Fault displays and the wheelchair drives slowly.	The controller has determined a fault during a previous turn-off process (Error code E41).	Turn the wheelchair off and back on.
ATTENDANT ACTIVE and  displays.	The Proportional or Digital Attendant control is active and can be used to drive the chair (Error code W05).	This is normal behavior.
Batteries draw excessive current when charging.	Battery failure. Electrical malfunction.	Have batteries checked for shorted cell. Replace if necessary. Contact Dealer/Invacare for service.

SYMPTOM	PROBABLE CAUSE	SOLUTIONS
Battery indicator flashes the charge level is low - immediately after recharge.	Battery failure.	Check batteries for shorted cell. Replace if necessary.
	Malfunctioning battery charger.	Contact Dealer/Invacare for Service.
	Electrical malfunction.	Contact Dealer/Invacare for Service.
Battery indicator flashes the charge level is low - too soon after being recharged.	Batteries not charged.	Have charger checked.
	Weak batteries.	Replace batteries if necessary. Refer to Replacing the Batteries on page 58.
Motor “chatters” or runs irregular.	Electrical malfunction.	Contact Dealer/Invacare for Service.
Only one drive wheel turns.	Electrical malfunction. One motor lock is disengaged.	Contact Dealer/Invacare for service. Engage motor lock.
Joystick erratic or does not respond as desired.	Damaged motor coupling.	Contact Dealer/Invacare for Service.
	Electrical malfunction.	Contact Dealer/Invacare for Service.
	Controller programmed improperly.	Contact Dealer/Invacare to have controller reprogrammed.
Wheelchair does not respond to commands.	Poor battery terminal connection.	Have terminals cleaned.
Power indicator off - even after recharging.	Electrical malfunction.	Contact Dealer/Invacare for Service.

Checking Battery Charge Level

The following “Do’s” and “Don’ts” are provided for your convenience and safety.

DON'T	DO
Don't perform any installation or maintenance without first reading this manual.	Read and understand this manual and any service information that accompanies a battery and charger before operating the wheelchair.
Don't perform installation or maintenance of batteries in an area that could be damaged by battery spills.	Move the wheelchair to a work area before cleaning terminals, or opening battery box.
Don't make it a habit to discharge batteries to the lowest level.	Recharge as frequently as possible to maintain a high charge level and extend battery life.
Don't use randomly chosen batteries or chargers.	Follow recommendations in this manual when selecting a battery or charger.
Don't put new batteries into service before charging.	Fully charge a new battery before using.
Don't tip or tilt batteries.	Use a carrying strap to remove, move or install a battery.
Don't tap on clamps and terminals with tools.	Push battery clamps on the terminals. Spread clamps wider if necessary.
Don't mismatch your battery and chargers.	Use ONLY a GEL charger for a GEL battery.

SECTION 5—WHEELCHAIR OPERATION

⚠ WARNING

After **ANY** adjustments, repair or service and before use, make sure that all attaching hardware is tightened securely - otherwise injury or damage may result.

Set-up of the Electronic Control Unit is to be performed only by a qualified technician. The final adjustments of the controller may affect other activities of the wheelchair. Damage to the equipment could occur under these circumstances.

Operating the Wheelchair

Turning the Power On/Off

NOTE: For this procedure, refer to FIGURE 5.1.

- To turn the power On, perform one of the following steps:

JOYSTICK	ACTION
MPJ+	Move the On/Off switch Forward to the On position.
SPJ+	Press the On/Off button.

- Turning the power Off can be achieved by performing one of the following steps:

JOYSTICK	ACTION
MPJ+	Move the On/Off switch Back to the Off position.
SPJ+	Press the On/Off button.

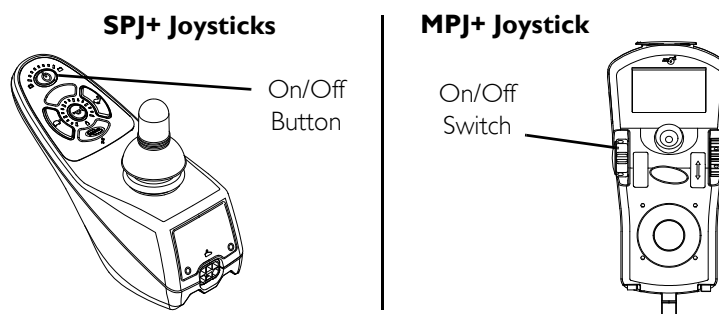

FIGURE 5.1 Turning the Power On/Off

Using the Joystick to Drive the Wheelchair

NOTE: For this procedure, refer to FIGURE 5.2 on page 31.

The joystick is located on the joystick housing and provides smooth control of speed and direction. It is equipped with 360 degrees of mobility for ease of operation. The joystick is spring-loaded, and automatically returns to the upright (neutral) position when released. Pushing the joystick in a given direction causes the wheelchair to move in that direction.

The joystick has proportional drive control, meaning that the further it is pushed from the upright (neutral) position, the faster the wheelchair moves. The maximum speed, however, is limited by the setting of the speed-control knob.

To slow the wheelchair to a stop, simply release the joystick. The wheelchair has automatic speed and direction compensation to minimize corrections.

When first learning to drive, select a slow speed and try to drive the wheelchair as slowly as possible by pushing the joystick slightly forward. This exercise will help you learn to utilize the full potential of the proportional control and allow you to start and stop smoothly.

To drive the wheelchair, perform the following:

1. Adjust speed control knob to the appropriate setting.
2. Turn the power On. Refer to [Turning the Power On/Off](#) on page 30.
3. Maneuver the joystick in the following manner:

MOVEMENT	ACTION
FORWARD	Push joystick forward, towards the front of the wheelchair.
REVERSE	Pull joystick back, towards the rear of the wheelchair.
Turn RIGHT	Move joystick toward the right side of the wheelchair.
Turn LEFT	Move joystick toward the left side of the wheelchair.
STOP	Release the joystick and the wheelchair will slow to a stop.

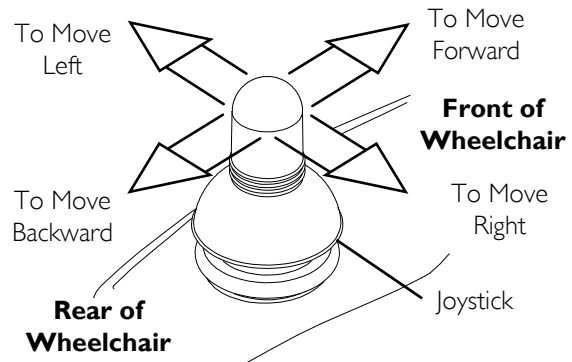

FIGURE 5.2 Using the Joystick to Drive the Wheelchair

NOTE: For specific information about the joystick installed on the wheelchair, refer to one of these procedures:

- [SPJ+, MK6i SPJ+ w/PSS and MK6i SPJ+ w/ACC Joystick Switches and Indicators](#) on page 32.
- [MPJ+ Joystick Switches and Indicators](#) on page 34.

SPJ+, MK6i SPJ+ w/PSS and MK6i SPJ+ w/ACC Joystick Switches and Indicators

NOTE: For the following information, refer to FIGURE 5.3.

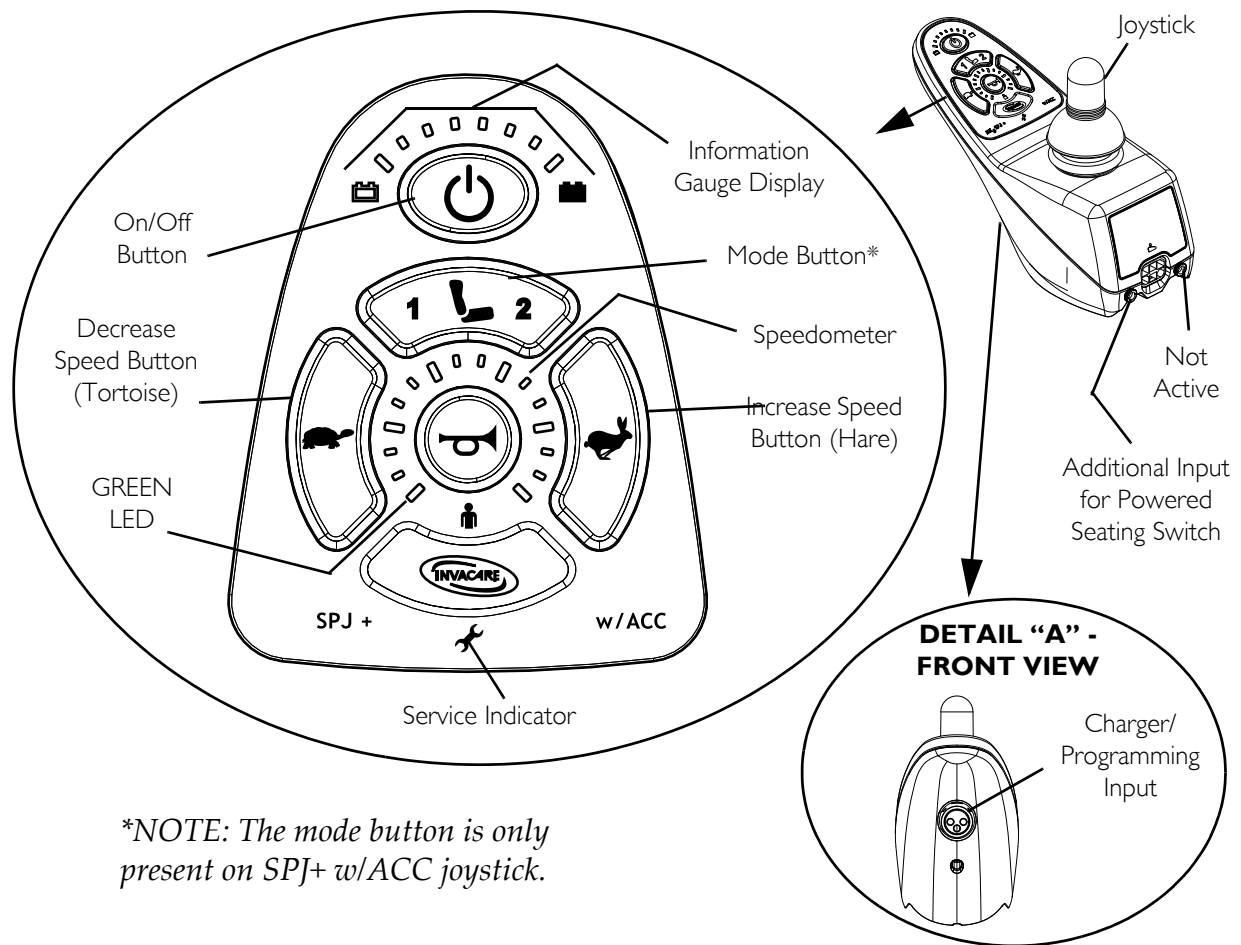

*NOTE: The mode button is only present on SPJ+ w/ACC joystick.

FIGURE 5.3 SPJ+, MK6i SPJ+ w/PSS and MK6i SPJ+ w/ACC Joystick Switches and Indicators



On/Off Button









This button is located at the front of the joystick housing. It is used to turn the wheelchair On and Off, to remove the joystick from sleep mode (if programmed) and to lock or unlock the joystick (if programmed).

Speedometer

The speedometer is used to show the maximum speed. The right-most LED indicates current maximum speed setting. The bottom left GREEN LED flashes to indicate that the joystick is in speed limit mode. Speed limit mode limits the drive speed to a pre-programmed value, typically when the seat has been elevated and the wheelchair is required to drive at 20% speed.

Speed Control Buttons

The speed control buttons (tortoise button () and hare button () are used to set and adjust the maximum speed.

1. To adjust the speed, perform one of the following:
 - Adjust Speed in 20% Increments (5 Speed Mode) - Press the tortoise button () or hare button () to decrease/increase the speed in 20% increments. The larger bars in the speedometer will light.
 - Adjust Speed in Smaller Increments (VSP Mode) - Perform the following steps:
 - i. Press and hold both the tortoise button () and hare button () until the joystick beeps.
 - ii. Perform one of the following:
 - Press the tortoise button () or hare button () to decrease/increase the speed in 20% increments. The larger bars in the speedometer will light.
 - Press and hold the tortoise button () or hare button () to decrease/increase the speed in smaller increments. The smaller bars in the speedometer will light.

Joystick

The joystick has proportional drive control, meaning that the further the joystick is pushed from the upright (neutral) position, the faster the wheelchair or seat moves. Your top speed, however, is limited by the programmed settings.

To slow the wheelchair to a stop, simply release the joystick. The wheelchair has automatic speed and direction compensation to minimize corrections.

Charger/Programming Input

The charger/programming input is located at the front of the joystick housing. This provides easy access for charging the wheelchair batteries. This port also serves as the Remote Programmer Communication connection. Driving is prevented while the system is charging.

Service Indicator

The AMBER service indicator will light when an error or fault occurs. Refer to [Service Indicator Light Diagnostics](#) on page 30 for a listing of the flash codes and what they indicate.

Information Gauge Display

The information gauge display is located on the front of the joystick housing and provides the following information to the user on the status of the wheelchair:

1. Power is On.
2. True state-of-battery-charge, including notification of when the battery requires charging:
 - A. GREEN LEDs are lit, indicating well charged batteries.
 - B. AMBER LEDs are lit, indicating batteries are moderately charged. Recharge batteries before taking a long trip.
 - C. RED LEDs are lit, indicating batteries are running out of charge. Recharge batteries as soon as possible.

The Information Gauge display also serves as a system diagnostic device when a fault is detected by the control module. A specific number of flashes of the LEDs indicate the type of fault detected. Refer to [Service Indicator Light Diagnostics](#) on page 30 for the diagnostic indications of the wheelchair status.

MPJ+ Joystick Switches and Indicators

NOTE: For this procedure, refer to FIGURE 5.4 on page 34.

Drive Select Toggle Switch

The drive select toggle switch is located on the left side, below the LCD. The drive select position is momentary, meaning that it will return to the neutral position after a selection is made.

This switch allows the operator to select the type of operation or performance which best suits a particular control need or situation. The DRIVE 1 program uses performance values which are independent of those used for the DRIVE 2 or 3 or 4 program. As an example, an operator may have a control need for spasticity in the morning and a very different need in the afternoon. DRIVE 1 can be programmed for higher speeds and quicker response while DRIVE 2 can be programmed for slower speeds and less responsiveness or vice versa. The other two drive programs could be indoor and outdoor versions of DRIVE 1 and DRIVE 2.

Selecting the Drive Mode

1. Move the toggle up and release. DRIVE 1 (**D1**) will appear on LCD.
2. Move the toggle up and release again. DRIVE 2 (**D2**) will appear on LCD.
3. Move the toggle up and release again. DRIVE 3 (**D3**) will appear on LCD.
4. Move the toggle up and release again. DRIVE 4 (**D4**) will appear on LCD.
5. Move the toggle up and release one more time to select DRIVE 1 (**D1**).

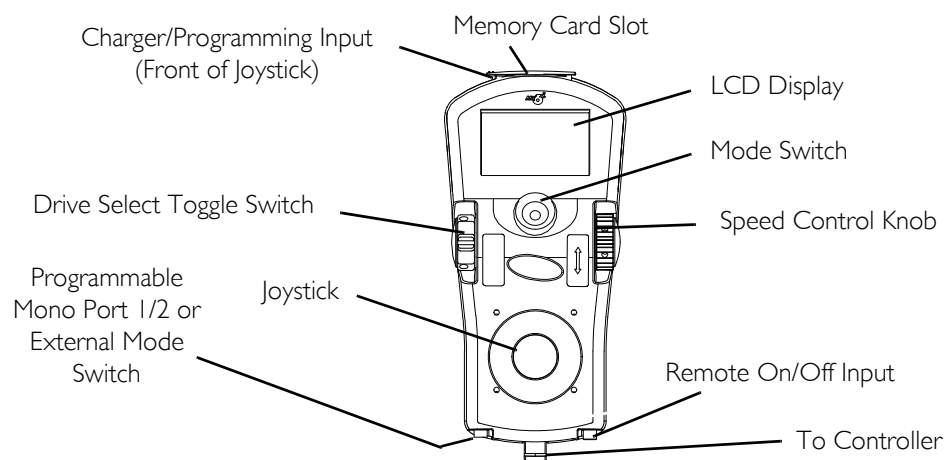

FIGURE 5.4 MPJ+ Joystick Switches and Indicators

Speed Control

The speed control knob is located on the side of the joystick housing.

1. Rotate the knob clockwise (forward) to increase the speed of the wheelchair to the programmed max speed.
2. Rotate the knob counterclockwise (backward) to decrease the speed of the wheelchair to the programmed max speed.

Joystick

The joystick has proportional drive control, meaning that the further the joystick is pushed from the upright (neutral) position, the faster the wheelchair or seat moves. Your top speed, however, is limited by the programmed settings.

To slow the wheelchair to a stop, simply release the joystick. The wheelchair has automatic speed and direction compensation to minimize corrections.

Charger/Programming Input

The charger/programming input is located at the front of the joystick housing. This provides easy access for charging the wheelchair batteries. This port also serves as the Remote Programmer Communication connection. Driving is prevented while the system is charging.

LCD Display Screens

The LCD Display is located in front of the joystick and provides information on the status of the wheelchair through a backlit display. The LCD display is readable in both bright sunlight and complete darkness.

Splash Screen

NOTE: For this procedure, refer to FIGURE 5.5.

This screen is displayed at startup of the joystick for about 2 seconds. This screen displays the software version and date information.

After this screen, the joystick displays the Main Screen.



FIGURE 5.5 LCD Display Screens - Splash Screen

Main Screen

NOTE: For this information, refer to FIGURE 5.6 on page 36.







During normal operation, the active drive is displayed in the upper half of the LCD display. Battery charge level is shown in the Battery Gauge Display (BGD) located on the right side of the LCD display. At full charge, solid blocks fill in all ten segments between E (Empty) and F (Full). As the battery becomes discharged, the top most segments will progressively disappear until no segments appear between E and F. At this level, the user should charge the batteries as soon as possible.

The lower half of the LCD display is the Information Center. The Information Center displays current data on the wheelchair.

Refer to [LCD Display](#) table on page 35 for descriptions of information shown.

LCD DISPLAY

ITEM	DESCRIPTION
DRIVE NAME	<p>This field shows the currently selected Drive's Name. Available choices are as follows:</p> <p>D1 Drive 1*</p> <p>D2 Drive 2*</p> <p>D3 Drive 3*</p> <p>D4 Drive 4*</p> <p>X "No Drive" selected via the programmer.</p> <p><i>*NOTE: Drive names can be customized. Actual drive names may display differently.</i></p>
BATTERY LEVEL INDICATOR	<p>This symbol shows the Battery Level and will change depending on the available battery power.</p> <p>This indicator is shown on every screen.</p>
STATUS MESSAGE	<p>This area displays status or instructions.</p>

ITEM	DESCRIPTION
STATUS INDICATOR	The status indicator will show a “Warning” (exclamation point inside a triangle) indicator when the chair has a condition that requires attention. The status indicator will show a “STOP” sign when a serious condition exists. The chair will not be allowed to operate. The status indicator shows an Attendant Icon if the attendant’s override switch is active.
MODES	The dotted-box shows the area that contains the available “modes” in the currently selected drive. The modes are programmed for each drive and are based upon the configuration of the chair. These modes are highlighted when the Mode is active. The operator changes modes by pressing the Mode Select Switch. The available modes are as follows: <ul style="list-style-type: none">  Drive Mode (1 through 4)  Automatic Positioning  Actuator Control Switch Mode (4-switch, 4-switch 2 levels, etc.)  ECU Output Activated (1 through 4)  RIM Mode Activated  Drive Select Mode Activated  No Driving

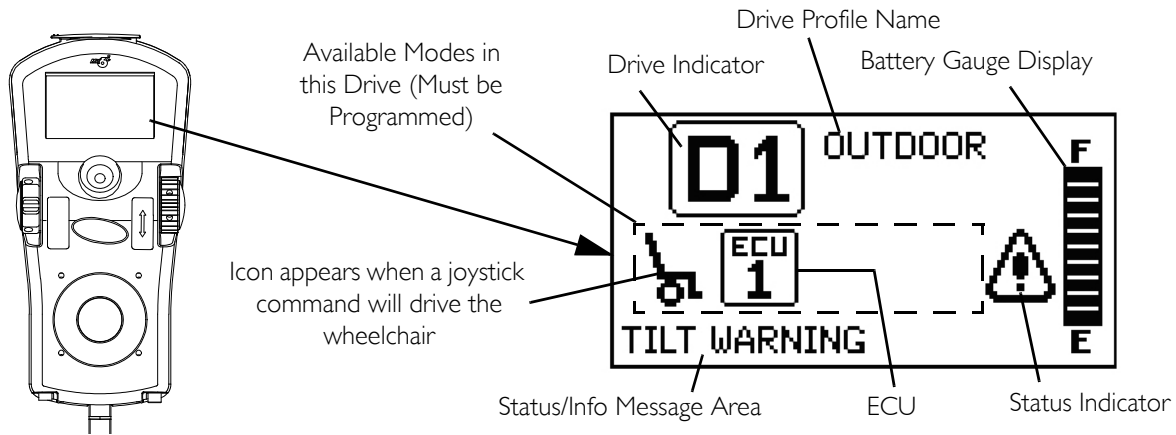

FIGURE 5.6 LCD Display Screens - Main Screen

Driving Screen

NOTE: For this procedure, refer to FIGURE 5.7.

This screen is shown when the operator issues a drive command and the Drive Icon on the main screen was highlighted.

NOTE: The Drive’s name, warning/info message, status icon and battery indicator are displayed on this screen.



FIGURE 5.7 LCD Display Screens - Driving Screen

Connected Devices Screen

NOTE: For this procedure, refer to FIGURE 5.8.

This screen is displayed if the Mode Select switch is held active for about 10 seconds. This screen shows an icon that represents any additional devices that are connected to the chair.

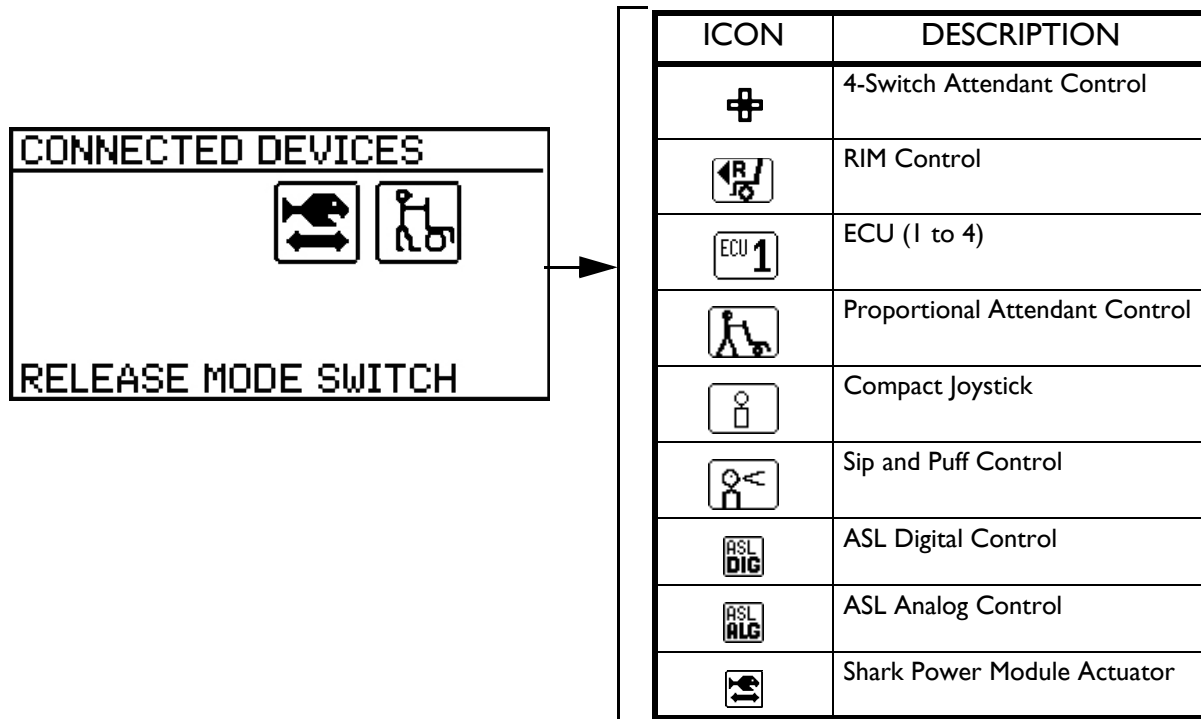

FIGURE 5.8 LCD Display Screens - Connected Devices Screen

Programmable Mono Port 1/2 or External Mode Switch

The programmable mono port or external mode switch input is located at the rear of the joystick on the left side. The programmable mono port input offers the choice of three options:

- Remote drive select
- Remote stop/mode (reset) input
- Single actuator input

The single switch functions operate through mono port 1. An optional y-cable allows a second programmable function through mono port 2.

Remote Stop Switch

The remote stop switch is used to stop the wheelchair.

Remote Mode (Reset) Switch

The remote mode reset switch functions the same way as the mode switch. Refer to [Mode Switch](#) on page 38.

Remote On/Off Switch

The remote On/Off switch input is located at the rear of the joystick on the right side and allows the power switch to be operated by an ability switch (normally open momentary switch with mono plug). To use the remote On/Off feature, the Drive Select/On/Off switch must be in the On position. Each activation of the ability switch will alternately turn the joystick On or Off.

Mode Switch

NOTE: For this procedure, refer to FIGURE 5.4 on page 34.

The mode switch is used to select the operating mode for the wheelchair. The mode switch is located on the joystick. A mode switch is needed whenever any of the following operating modes are programmed:

- Environmental Controls (ECU 1, ECU 2, ECU 3, ECU 4)*
- 3 Speed Mode in Digital 3 Speed (Slow, Medium, Full)
- Latched Modes
- Sleep Mode
- RIM Mode*
- Remote Drive Selection Mode*
- Tilt/Recline Mode*
- Information Center Display Selection (does not require Reset activation at power up)

If any of the above modes are selected, the control will require activation of the switch immediately after the power switch is turned On in order to enter the drive mode. The second line of the LCD will display - PRESS RESET.

**NOTE: In these modes, Standby Select allows the reset switch to be bypassed for users unable to activate the switch.*

Memory Card Slot

The memory card slot is used with the basic or professional memory card for saving or reading wheelchair parameters.

Repositioning Joystick

Van Seats

NOTE: For this procedure, refer to FIGURE 5.9.

NOTE: Take note of position and orientation of mounting hardware for reinstalling the joystick assembly.

1. Turn the adjustment lock lever to release the joystick mounting tube from the mounting bracket.
2. Remove the joystick mounting tube from the wheelchair.
3. Remove the three hex mounting screws, bushings and locknuts that secure the mounting bracket to the three mounting holes on the armrest plate.

NOTE: The mounting bracket is mounted to the inside of the armrest plate.

4. Reposition the mounting bracket on the opposite armrest plate.
5. Using the three hex mounting screws, bushings and locknuts secure the mounting bracket to the three mounting holes of the armrest plate.
6. If necessary, perform the following to reposition the adjustment lock:
 - A. Slide the adjustment lock from the mounting bracket.
 - B. Rotate adjustment lock 180° and slide adjustment lock over the opposite end of the mounting bracket.
7. Slide joystick mounting tube through the mounting bracket to the desired position and secure adjustment lock to tube by turning lever on adjustment lock.

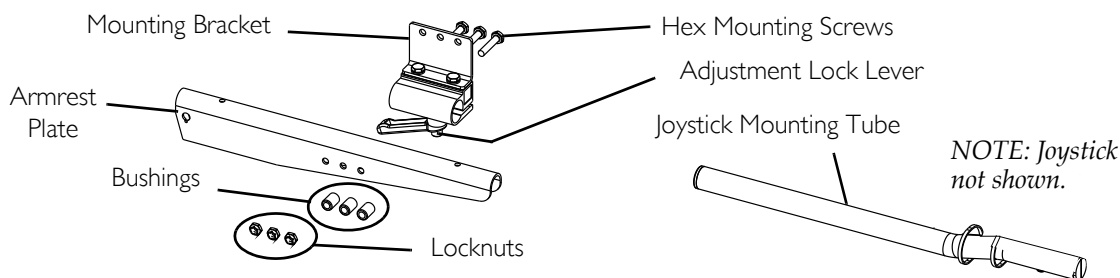

FIGURE 5.9 Repositioning Joystick - Van Seats

Adjustable ASBA Seats

NOTE: For this procedure, refer to FIGURE 5.10.

1. Turn the adjustment lock lever to release the joystick mounting tube from the mounting bracket.
2. Remove the joystick from the wheelchair.
3. Remove the three hex screws that secure both halves of the mounting bracket to the arm tube.
4. Reposition mounting bracket on opposite arm tube ensuring the threaded plate of the mounting bracket is on the inside of the arm tube as shown in FIGURE 5.10.
5. Using the three hex mounting screws and washers, secure both halves of the mounting bracket to the arm tube.
6. Slide the joystick mounting tube through the mounting bracket to the desired position.
7. Turn the adjustment lock lever to secure the joystick mounting tube into the mounting bracket.

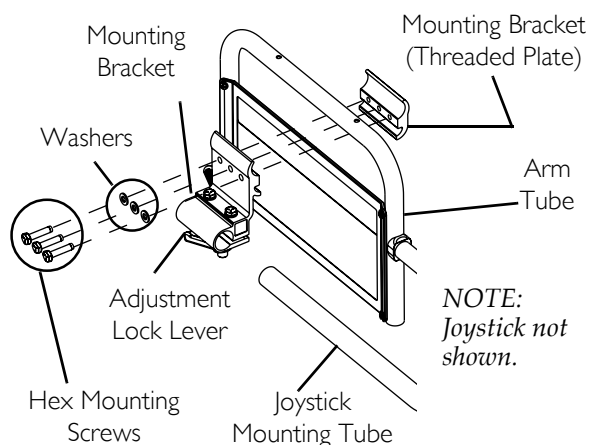

FIGURE 5.10 Repositioning Joystick - Adjustable ASBA Seats

Disconnecting/Connecting the Joysticks

NOTE: For this procedure, refer to FIGURE 5.11 on page 40.

NOTE: The joystick connector is located at the rear of the seat frame.

SPJ+ Joysticks

Disconnecting

1. Hold the light GREY collar portion of the joystick connector with one hand and the controller connector on the wheelchair in the other and disconnect them by pulling them apart.

Connecting

⚠ WARNING

The joystick connector and controller connector fit together in one way only; DO NOT force them together.

1. Hold the light GREY collar portion of the joystick connector with one hand and the controller connector on the wheelchair in the other and align them.
2. Lightly push to engage the joystick connector and the controller connector.

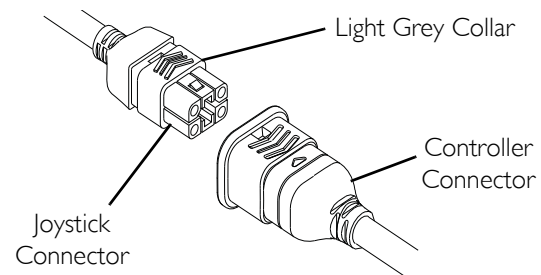

FIGURE 5.11 Disconnecting/Connecting the Joysticks - SPJ+ Joysticks

MPJ+ Joysticks

NOTE: For this procedure, refer to FIGURE 5.12.

Disconnecting

1. Pull the latch away from the joystick connector.
2. Disconnect the joystick connector from the remaining connectors.

Connecting

1. Ensure the latch is pulled away from the joystick connector.
2. Connect the joystick connector to the other connectors.
3. Push the latch in to secure the joystick connector to the other connectors.

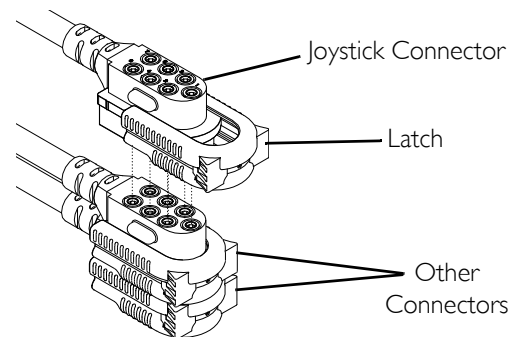

FIGURE 5.12 Disconnecting/Connecting the Joysticks - MPJ+ Joysticks

SECTION 6—SEAT - TDX SC ONLY

⚠ WARNING

After ANY adjustments, repair or service and before use, make sure that all attaching hardware is tightened securely - otherwise injury or damage may result.

Before performing any maintenance, adjustment or service, verify that ON/OFF switch on the joystick is in the OFF position.

Removing/Installing or Tilting the Seat Assembly

Removing/Installing the Seat Assembly - Wheelchairs with Latch Bars Only

NOTE: For this procedure, refer to FIGURE 6.1 on page 41.

Removing

1. Disconnect the joystick cable at rear of seat. Refer to Disconnecting/Connecting the Joysticks on page 40.

NOTE: The latch bar will be located behind the front seat posts on wheelchairs with adjustable ASBA seats and in front of the front seat posts on wheelchairs with van seats.

2. Push down on the latch bar underneath front of seat.
3. Rotate seat assembly backward.
4. Slide the seat assembly forward to disengage seat from pivot brackets located in the rear.

Installing

1. Position the seat in the rear pivot brackets as shown in FIGURE 6.1.
2. Rotate seat assembly forward.
3. When seat is lowered, engage seat brackets into seat clevis pins.

NOTE: TDX SC with Transport Brackets (TRBKTS) shown.

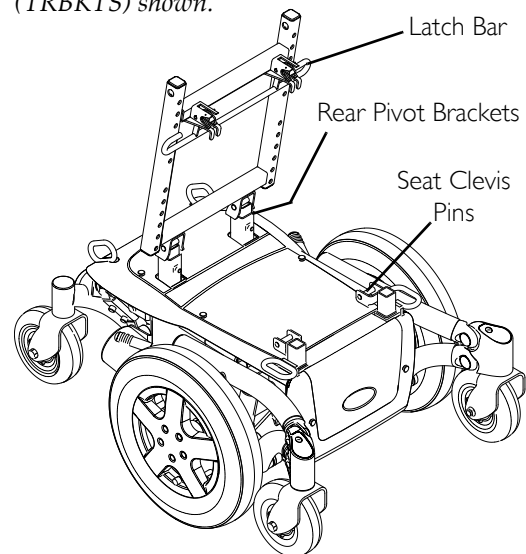

⚠ WARNING

When reinstalling the seat verify that the seat brackets are engaged with the seat clevis pins by pulling up on the latch bar.

4. Pull up on latch bar to verify that brackets are engaged with seat clevis pins.

FIGURE 6.1 Removing/Installing the Seat Assembly - Wheelchairs with Latch Bars Only

Tilting the Seat Assembly - Wheelchairs without Latch Bar Only

⚠ WARNING

Make sure power to the wheelchair is OFF before performing this procedure.
Never leave the seat assembly in the UP/OPEN position unless necessary to perform a procedure on the wheelchair - otherwise injury or damage may result.
After ANY adjustments, repair or service and before use, make sure all attaching hardware is tightened securely - otherwise injury or damage may result.

NOTE: For this procedure, refer to FIGURE 6.2 on page 43.

NOTE: Removing the seat is not necessary to access the battery compartment. The seat assembly tilts back and props into place to provide access to the batteries and the underside of the seat.

Tilting the Seat Assembly Back

1. Place the wheelchair in a well ventilated area where work can be performed without risking damage to carpeting or floor covering.
2. If necessary, tilt seat back 20° to 25°.
3. Verify the joystick ON/OFF switch is in the OFF position and disconnect joystick cable.
4. Engage the motor release levers. Refer to Disengaging/Engaging Motor Lock Levers on page 44.
5. Remove front rigging. Refer to seating system owners manual.
6. Remove the two mounting screws and washers securing the seat frame plate to the front seat posts.
7. Firmly grasp the front edge of the seat assembly, slowly tilt the seat assembly back into the UP/OPEN position.
8. Remove prop rod from the clip located on the Formula CG frame and engage the prop rod end into the front seat post.
9. Gently allow weight of seat assembly to be supported by the prop rod.

NOTE: Only leave the seat assembly in the UP/OPEN position while performing any necessary procedures. Always lower the seat assembly to the DOWN/CLOSED position when not servicing the wheelchair. Ensure the seat is locked in place before using.

Tilting the Seat Assembly Forward

1. Using one hand, firmly grasp the front edge of the seat assembly and lift until seat assembly is no longer supported by the prop rod.
2. Disengage the prop rod from the front seat post and secure into clip.
3. Using both hands, slowly tilt the seat assembly FORWARD into the DOWN/CLOSED position.

⚠ WARNING

Ensure the two mounting screws, washers and locknuts are securely tightened and the seat frame is locked in place before use - otherwise injury or damage may result.

4. Using the two mounting screws, washers and locknuts, secure the seat frame plate to the two front seat posts.

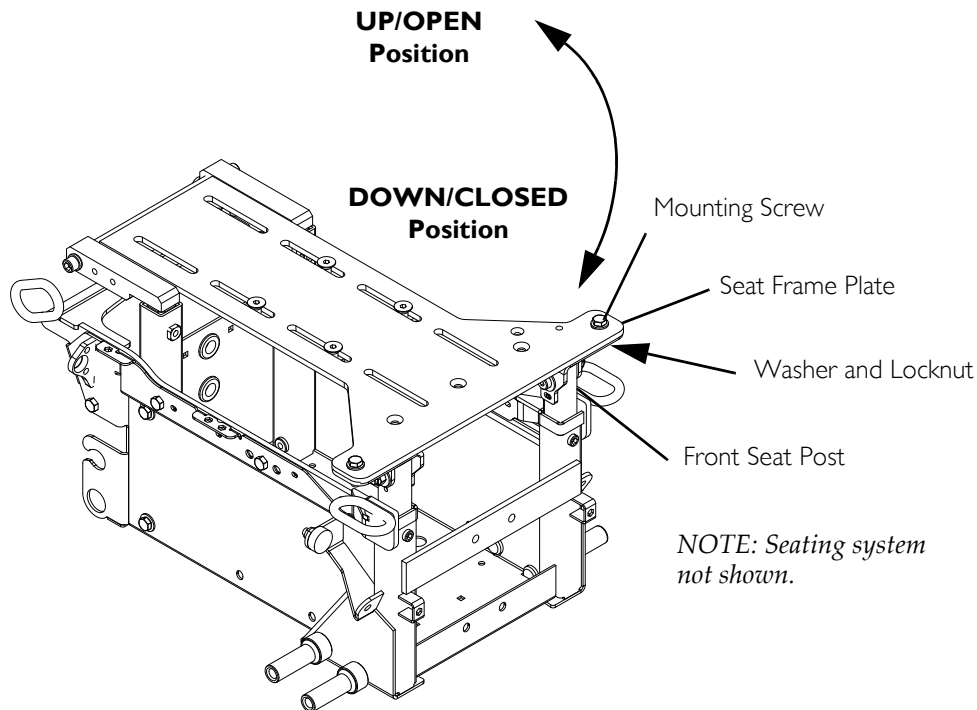

FIGURE 6.2 - Tilting the Seat Assembly - Wheelchairs without Latch Bar Only

SECTION 7—MOTOR LOCKS

⚠ WARNING

After ANY adjustments, repair or service and before use, make sure that all attaching hardware is tightened securely - otherwise injury or damage may result.

CAUTION

As with any vehicle, the wheels and tires should be checked periodically for cracks and wear, and should be replaced.

Disengaging/Engaging Motor Lock Levers

⚠ WARNING

DO NOT engage or disengage motor locks until the power is in the OFF position.

CAUTION

Ensure both motor release levers are fully engaged before driving the wheelchair

NOTE: For this procedure, refer to FIGURE 7.1.

NOTE: Motor lock disengagement/engagement allows free-wheeling or joystick controlled operation. Free-wheeling allows an assistant to maneuver the wheelchair without power.

NOTE: Motor lock levers are located between the rear caster assembly and drive wheel on both sides of the wheelchair.

1. Perform one of the following (FIGURE 7.1):

- Disengage (PUSH) - Pull motor lock levers out, away from wheelchair to disengage the motor.
- Engage (DRIVE) - Push motor lock levers in, towards the wheelchair to engage the motor.

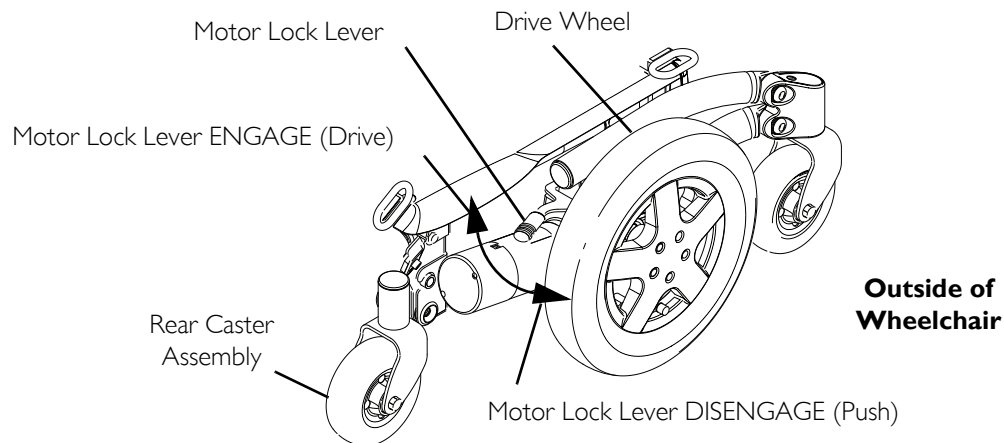

FIGURE 7.1 Disengaging/Engaging Motor Lock Levers

SECTION 8—WHEEL LOCKS

⚠ WARNING

After ANY adjustments, repair or service and before use, make sure that all attaching hardware is tightened securely - otherwise injury or damage may result.

CAUTION

DO NOT use the wheel locks when the wheelchair power is on and the clutches are engaged - otherwise damage to the wheelchair may result.

NOTE: Use the wheel locks whenever the clutches are disengaged and the wheelchair is being pushed.

Disengaging/Engaging the Wheel locks

NOTE: For this procedure, refer to FIGURE 8.1.

Engaging

1. Push handle forward away from tire to engage wheel lock.
2. Repeat STEP 1 for opposite wheel.

Disengaging

1. Pull handle back toward tire to disengage wheel lock.
2. Repeat STEP 1 for opposite wheel.

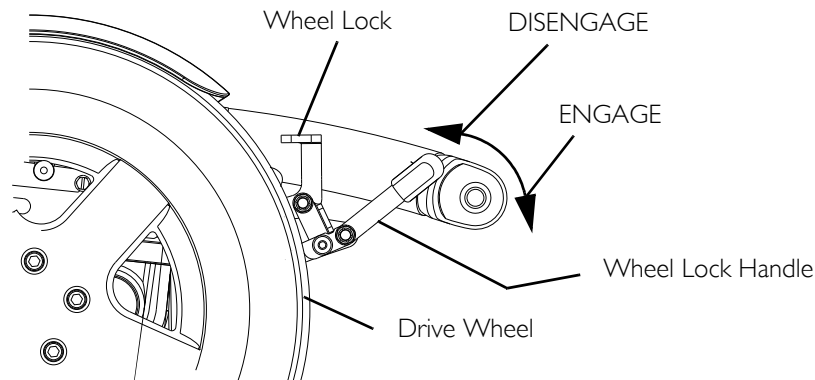

FIGURE 8.1 Disengaging/Engaging the Wheel locks

SECTION 9—FOOTBOARD ASSEMBLY

⚠ WARNING

After **ANY** adjustments, repair or service and before use, make sure that all attaching hardware is tightened securely - otherwise injury or damage may result.

Before performing any maintenance, adjustment or service, verify that **ON/OFF** switch on the joystick is in the **OFF** position.

DO NOT stand on the flip-up footboard. When getting in or out of the wheelchair, make sure that the flip-up footboard is in the upward position.

LIMITED CLEARANCE BETWEEN FOOTBOARD AND CASTER - The user's feet **MUST** remain on the footboard while operating the wheelchair. If the user's feet are allowed to rest off the side of the footboard they may come in contact with the caster possibly resulting in injury.

Removing/Installing the Footboard

NOTE: For this procedure, refer to FIGURE 9.1 on page 46.

Removing

1. Remove the socket head screw, three washers, spacer and locknut that secures the footboard to the footboard support.
2. Remove the footboard from the footboard support.

Installing

⚠ WARNING

Pinch point may occur when rotating the footboard assembly.

1. Position the footboard onto the footboard support so that the mounting holes in the wheelchair frame align with the desired mounting holes in the footboard support.
2. Using the socket head screw, three washers, spacer and locknut secure the footboard to the footboard support.

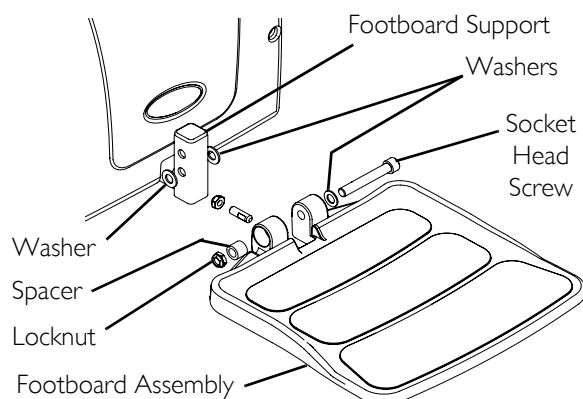

FIGURE 9.1 Removing/Installing the Footboard

Adjusting the Footboard Angle

NOTE: For this procedure, refer to FIGURE 9.2.

1. Loosen the jam nut and set screw located underneath on the rear of the footplate.
2. Adjust the mounting screw in or out to obtain the desired footboard angle.
3. Thread the jam nut inward until it is flush with the footboard bracket.
4. Securely tighten the jam nut and washer to secure the mounting screw in place.

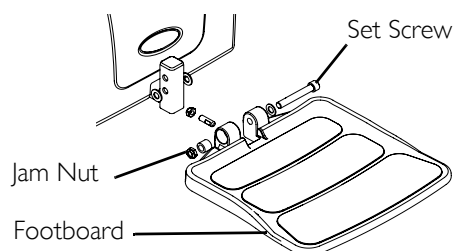

FIGURE 9.2 Adjusting the Footboard Angle

SECTION 10—FORKS

⚠ WARNING

After ANY adjustments, repair or service and before use, make sure that all attaching hardware is tightened securely - otherwise injury or damage may result.

CAUTION

As with any vehicle, the wheels and tires should be checked periodically for cracks and wear, and should be replaced.

Adjusting Forks

NOTE: For this procedure, refer to FIGURE 10.1.

1. Remove the retaining screw that secures the headtube cover in place.
2. Remove the headtube cover (not shown) from the caster headtube.
3. To properly tighten caster journal system and guard against flutter, perform the following check:
 - A. Tip back the wheelchair to floor.
 - B. Pivot both forks and casters to top of their arc simultaneously.
 - C. Let casters drop to bottom of arc (wheels should swing once to one-side, then immediately rest in a straight downward position).
 - D. Adjust locknuts according to freedom of caster swing.
4. Test wheelchair for maneuverability.
5. Readjust locknuts if necessary, and repeat STEPS 1-3 until correct.
6. Snap headtube cover into the caster headtube.
7. Reinstall retaining screws.

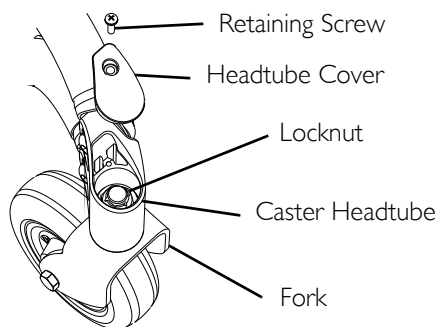

FIGURE 10.1 Adjusting Forks

SECTION 11—WHEELS AND SHROUDS

⚠ WARNING

After any adjustments, repair or service and before use, make sure that all attaching hardware is tightened securely - otherwise injury or damage may result.

Before performing any maintenance, adjustment or service verify that On/Off switch on the joystick is in the Off position.

Replacing the Flat Free Tires on the Wheel Rim

⚠ WARNING

DO NOT attempt to replace flat free tires. This procedure **MUST** be performed by a qualified technician.

NOTE: During initial use of the wheelchair, the user may experience flat spots on the wheels. Flat spots will vanish with continued use of the wheelchair.

Removing/Installing the Top Shroud

Wheelchairs without Elevating Seat

NOTE: For this procedure, refer to FIGURE 11.1.

NOTE: Reverse this procedure to install the top shrouds

1. Remove or tilt the seat back. Refer to [Removing/Installing or Tilting the Seat Assembly](#) on page 41.
2. Remove the two thumb screws securing the rear half of the top shroud to the wheelchair frame.
3. Pulling up, remove the rear half of the top shroud.
4. Remove the two thumb screws securing the front half of the top shroud to the wheelchair frame.
5. Pulling up, remove the front half of the top shroud.

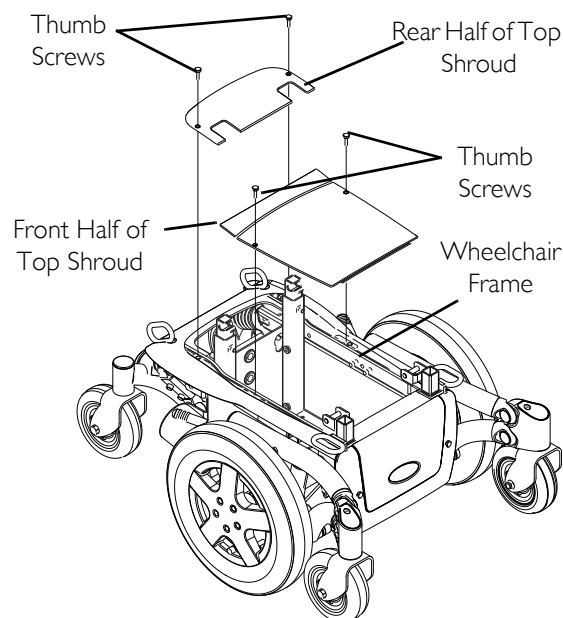

FIGURE 11.1 Removing/Installing the Top Shroud - Wheelchairs without Elevating Seat

Wheelchairs with Elevating Seat

NOTE: For this procedure, refer to FIGURE 11.2.

NOTE: Reverse this procedure to install the top shroud.

1. Elevate the seat. Refer to the seating system owners manual.
2. Remove the four thumb screws securing the rear half of the top shroud to the wheelchair frame.
3. Pulling up, remove the rear half of the top shroud.
4. Pulling up, remove the front half of the top shroud.

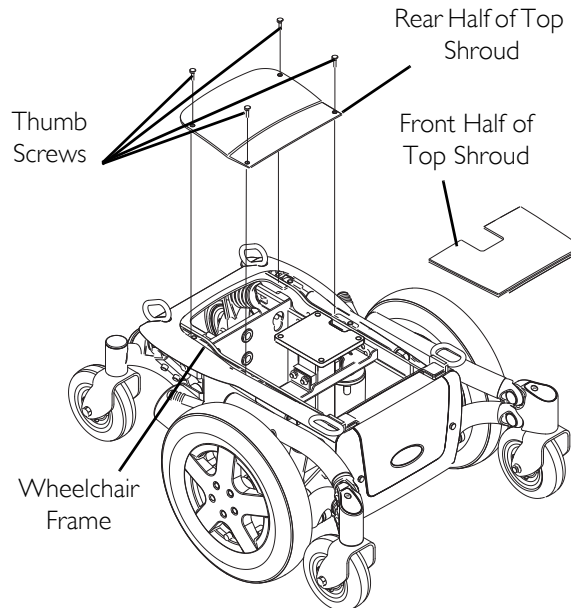

FIGURE 11.2 Removing/Installing the Top Shroud - Wheelchairs with Elevating Seat

SECTION 12—BATTERIES

Warnings For Handling and Replacing Batteries

⚠ WARNING

After any adjustments, repair or service and before use, make sure that all attaching hardware is tightened securely - otherwise injury or damage may result.

Make sure power to the wheelchair is **Off** before performing this section.

The use of rubber gloves is recommended when working with batteries.

Invacare strongly recommends that battery installation and battery replacement **ALWAYS** be done by a qualified technician.

UI batteries weigh 24 pounds each. Use proper lifting techniques (lift with your legs) to avoid injury.

Use UI batteries only. Failure to use the correct battery size and/or voltage may cause damage to your wheelchair and give you unsatisfactory performance.

ALWAYS use a battery handle/lifting strap when lifting a battery. It is the most convenient method and assures that the battery acid will not spill. It also helps to prolong the life of the battery.

DO NOT tip the batteries. Keep the batteries in an upright position.

NEVER allow any of your tools and/or battery cables to contact both battery posts at the same time. An electrical short may occur and serious personal injury or damage may occur.

The **POSITIVE (+)** battery cable **MUST** connect to the **POSITIVE (+)** battery terminal, otherwise serious damage will occur to the electrical system.

Connect same color connectors to each other (**RED to RED, BLACK to BLACK**).

DO NOT remove fuse or mounting hardware from **POSITIVE (+)** battery cable mounting screw. To replace the fuse, obtain and replace battery harness with fuse.

Wheelchairs should be examined during maintenance for signs of corrosion (water exposure, incontinence, etc.). Electrical components damaged by corrosion should be replaced **IMMEDIATELY**.

Wheelchairs that are used by incontinent users and/or are frequently exposed to water may require replacement of electrical components more frequently.

NOTE: If there is battery acid in the bottom of the battery tray or on the sides of the battery, apply baking soda to these areas to neutralize the battery acid. Before reinstalling the existing or new battery, clean the baking soda from the battery tray or battery being sure to avoid contact with skin and eyes. Determine source of contamination. NEVER install/reinstall a battery with a cracked or otherwise damaged case.

Using the Proper Batteries

NOTE: For this procedure, refer to FIGURE 12.1.

1. Place battery on ground/flat surface.
2. Visually draw a horizontal and vertical centerline through the middle of battery (FIGURE 12.1).
3. Position the battery so that the terminals are above the horizontal centerline.
4. Visually inspect the battery to ensure the correct position of the POSITIVE and NEGATIVE terminals (FIGURE 12.1).

⚠ WARNING

Batteries with terminal configuration as shown below MUST be used. Batteries that have the reverse terminal configuration MUST NOT be used - otherwise injury and damage may occur.

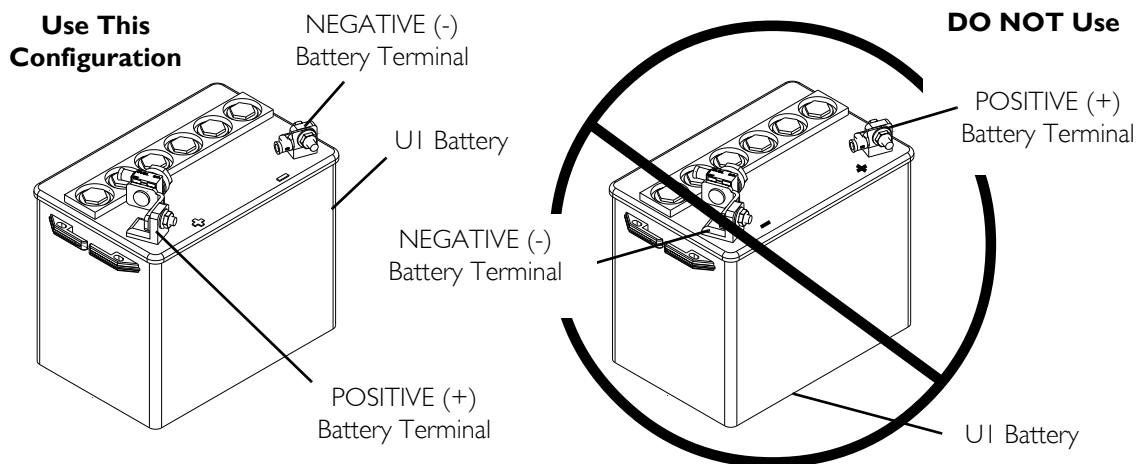

FIGURE 12.1 Using the Proper Batteries

Removing/Installing the Batteries

⚠ WARNING

ALWAYS use the battery handle when lifting the battery. It is the most convenient method and assures that the battery acid will not spill. It also helps to prolong the life of the battery.

DO NOT tip the batteries. Keep the batteries in an upright position.

NOTE: For this procedure, refer to FIGURE 12.2 on page 52.

NOTE: If there is battery acid in the bottom of the battery tray or on the sides of the battery, apply baking soda to these areas to neutralize the battery acid. Before reinstalling the existing or new battery, clean the baking soda from the battery tray or battery being sure to avoid contact with skin and eyes. Determine source of contamination. NEVER install/reinstall a battery with a cracked or otherwise damaged case.

NOTE: Have the following tools available:

TOOL	QTY	COMMENTS
7/16-INCH (6PT) BOX WRENCH	1	Not Supplied
DIAGONAL CUTTERS	1	Not Supplied

Removing/Installing the Batteries on TDX SC without Elevating Seat

NOTE: For this procedure, refer to FIGURE 12.2 on page 52.

Removing

1. Place the wheelchair in a well ventilated area where work can be performed without risking damage to carpeting or floor covering.
2. Verify the joystick On/Off switch is in the Off position and disconnect joystick cable (not shown). Refer to [Disconnecting/Connecting the Joysticks](#) on page 40.
3. Tilt the seat assembly to the up position. Refer to [Tilting the Seat Assembly - Wheelchairs without Latch Bar Only](#) on page 42.
4. Remove the battery shroud. Refer to [Removing/Installing the Top Shroud](#) on page 48.
5. Disconnect the rear battery from the controller (BLACK connector).
6. Disconnect the rear battery from the front battery (RED and BLACK connectors).
7. Lift rear and front battery out of the battery tray using the battery handles.

Installing

1. Verify the joystick On/Off switch is in the Off position and disconnect joystick cable. Refer to [Disconnecting/Connecting the Joysticks](#) on page 40.
2. Position the front battery in the front of the battery tray.
3. Position rear battery in rear of battery tray.

NOTE: Ensure that both batteries are properly seated and resting on the battery tray.

4. Connect the rear battery to the front battery (RED and BLACK connectors).
5. Connect the rear battery to the controller (BLACK connector).
6. Reinstall the top shroud. Refer to [Removing/Installing the Top Shroud](#) on page 85.
7. Lower the seat assembly to the down position. Refer to [Tilting the Seat Assembly - Wheelchairs without Latch Bar Only](#) on page 42.
8. Remove the battery shroud. Refer to [Removing/Installing the Top Shroud](#) on page 48.
9. Connect joystick cable (not shown). Refer to [Disconnecting/Connecting the Joystick](#) on page 121.

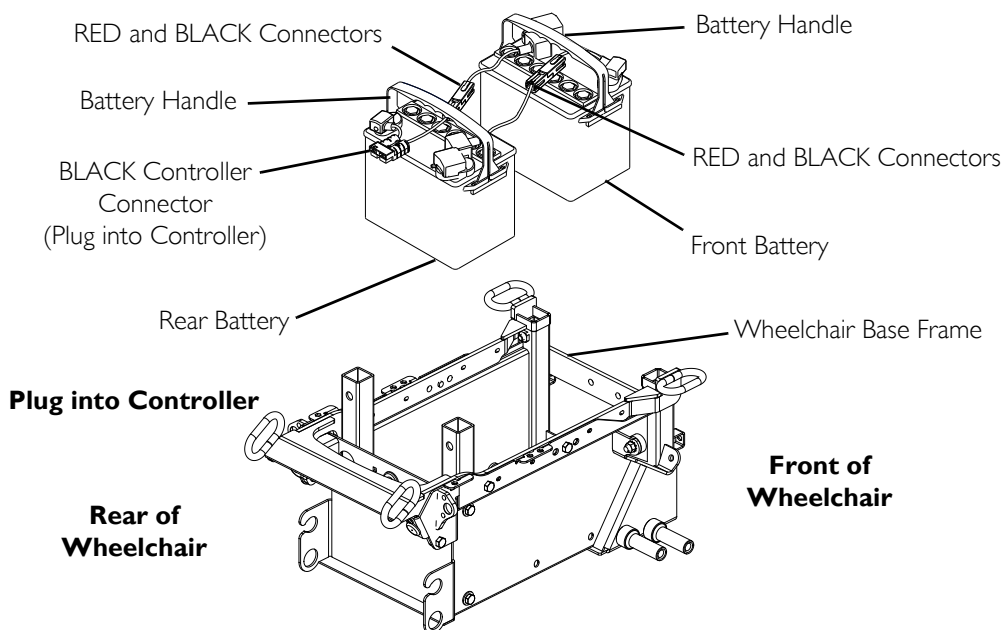

FIGURE 12.2 Removing/Installing the Batteries on TDX SC without Elevating Seat

Installing/Removing the Batteries on TDX SC with Elevating Seat or TDX Spree

NOTE: For this procedure, refer to FIGURE 12.3 on page 54.

Removing the Batteries

1. Place the wheelchair in a well ventilated area where work can be performed without risking damage to carpeting or floor covering.
2. Perform one of the following -
 - If there is power in the batteries, elevate the seat to the highest position. Refer to the owner's manual shipped with wheelchair.
 - If there is no power left in the batteries, Remove the seat frame from the wheelchair. Refer to Removing/Installing the Elevating Seat Assembly on page 57
3. Verify the joystick On/Off switch is in the Off position and disconnect joystick. Refer to Disconnecting/Connecting the Joysticks on page 40.
4. Remove the top shroud. Refer to Removing/Installing the Top Shroud on page 48.
5. Remove the right side docking pin bracket from the wheelchair frame.
6. Disconnect the rear battery from the controller (BLACK connector).
7. Disconnect the rear battery from the front battery (RED and BLACK connectors).
8. Using the battery handle, lift the rear battery up and tilt away from the wheelchair.
9. Using the battery handle, lift the front battery up and away from the wheelchair.
10. If replacing the batteries, remove the front and rear battery wiring harness. Refer to Disconnecting Battery Cables on page 58.

Installing the Batteries

NOTE: If replacing the batteries install the battery wiring harness. Refer to Connecting Battery Cables on page 59.

1. If replacing the batteries, install the front and rear battery wiring harness. Refer to Replacing the Batteries on page 58.
2. Using the battery handle and strap, position the front battery into the battery box.
3. Using the battery handle, position the rear battery into the battery box.
4. Connect the rear battery to the front battery (RED and BLACK connectors).
5. Connect the rear battery to the controller (BLACK connector).
6. Install the top shroud. Refer to Removing/Installing the Top Shroud on page 48.
7. Connect the joystick. Refer to Disconnecting/Connecting the Joysticks on page 40.
8. Verify the joystick On/Off switch is in the On position and lower the seat.

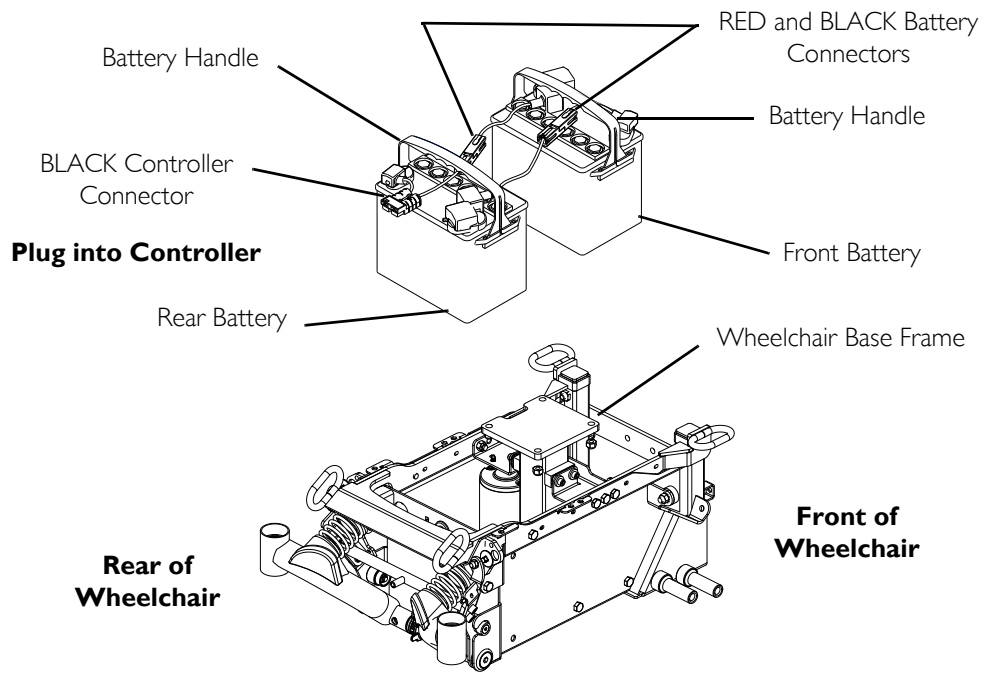

FIGURE 12.3 Installing/Removing the Batteries on TDX SC with Elevating Seat or TDX Spree

Installing/Removing the Batteries on TDX Spree with TRRO

⚠ WARNING

This procedure MUST be performed by a qualified technician.

NOTE: For this procedure, refer to FIGURE 12.4 on page 56.

Removing the Batteries

1. Place the wheelchair in a well ventilated area where work can be performed without risking damage to carpeting or floor covering.
2. Perform one of the following -
 - If there is power in the batteries, elevate the seat to the highest position. Refer to the owner's manual shipped with wheelchair.
 - If there is no power left in the batteries, Remove the seat frame from the wheelchair. Refer to [Removing/Installing the Elevating Seat Assembly](#) on page 57
3. Verify the joystick On/Off switch is in the Off position and disconnect joystick. Refer to [Disconnecting/Connecting the Joysticks](#) on page 40.
4. Remove the top shroud. Refer to [Removing/Installing the Top Shroud](#) on page 48.
5. Remove the four 5/16-18 X 2.00 socket head screws, .330 X .625 X .050 flat washers and 5/16-18 locknuts securing the docking pin bracket to the right and left docking pin mounting brackets.
6. Remove the two 1/4-20 X .75 socket head screws and flat washers securing the docking pin bracket to the elevating seat post.
7. Lift the docking pin bracket up and away from the wheelchair base frame.
8. Disconnect the rear battery from the controller (BLACK connector).
9. Disconnect the rear battery from the front battery (RED and BLACK connectors).
10. Using the battery handle, lift the rear battery up and tilt away from the wheelchair.
11. Using the battery handle, lift the front battery up and away from the wheelchair.
12. If replacing the batteries, remove the front and rear battery wiring harness. Refer to [Disconnecting Battery Cables](#) on page 58.

Installing the Batteries

NOTE: If replacing the batteries install the battery wiring harness. Refer to [Connecting Battery Cables](#) on page 59.

1. If replacing the batteries, install the front and rear battery wiring harness. Refer to [Replacing the Batteries](#) on page 58.
2. Using the battery handle and strap, position the front battery into the battery box.
3. Using the battery handle, position the rear battery into the battery box.
4. Connect the rear battery to the front battery (RED and BLACK connectors).
5. Connect the rear battery to the controller (BLACK connector).

NOTE: Ensure rubber pad is positioned between the docking pin bracket and the elevating seat post.

6. Position the docking pin bracket onto the wheelchair base frame so that the four tabs set into the notches in both sides of the wheelchair base frame.
7. Apply loctite[®] 242 to the threads of the four 5/16-18 X 2.00 socket head screws.
8. Loosely install the four 5/16-18 X 2.00 socket head screws, .330 X .625 X .050 flat washers and 5/16-18 locknuts, secure the docking pin bracket to the right and left docking pin mounting brackets.
9. Apply loctite 242 to the threads of the two 1/4-20 X .75 socket head screws.
10. Loosely install the two 1/4-20 X .75 socket head screws and flat washers, secure the docking pin bracket to the elevating seat post.

SECTION 12—BATTERIES

11. Securely tighten the four 5/16-18 X 2.00 socket head screws, .330 X .625 X .050 flat washers and 5/16-18 locknuts. Torque to 13ft-lbs \pm 20%.
12. Securely tighten the two 1/4-20 X .75 socket head screws and flat washers. Torque to 75i-/lbs \pm 20%.
13. Install the top shroud. Refer to [Removing/Installing the Top Shroud](#) on page 48.
14. Connect the joystick. Refer to [Disconnecting/Connecting the Joysticks](#) on page 40.
15. Verify the joystick On/Off switch is in the On position and lower the seat.

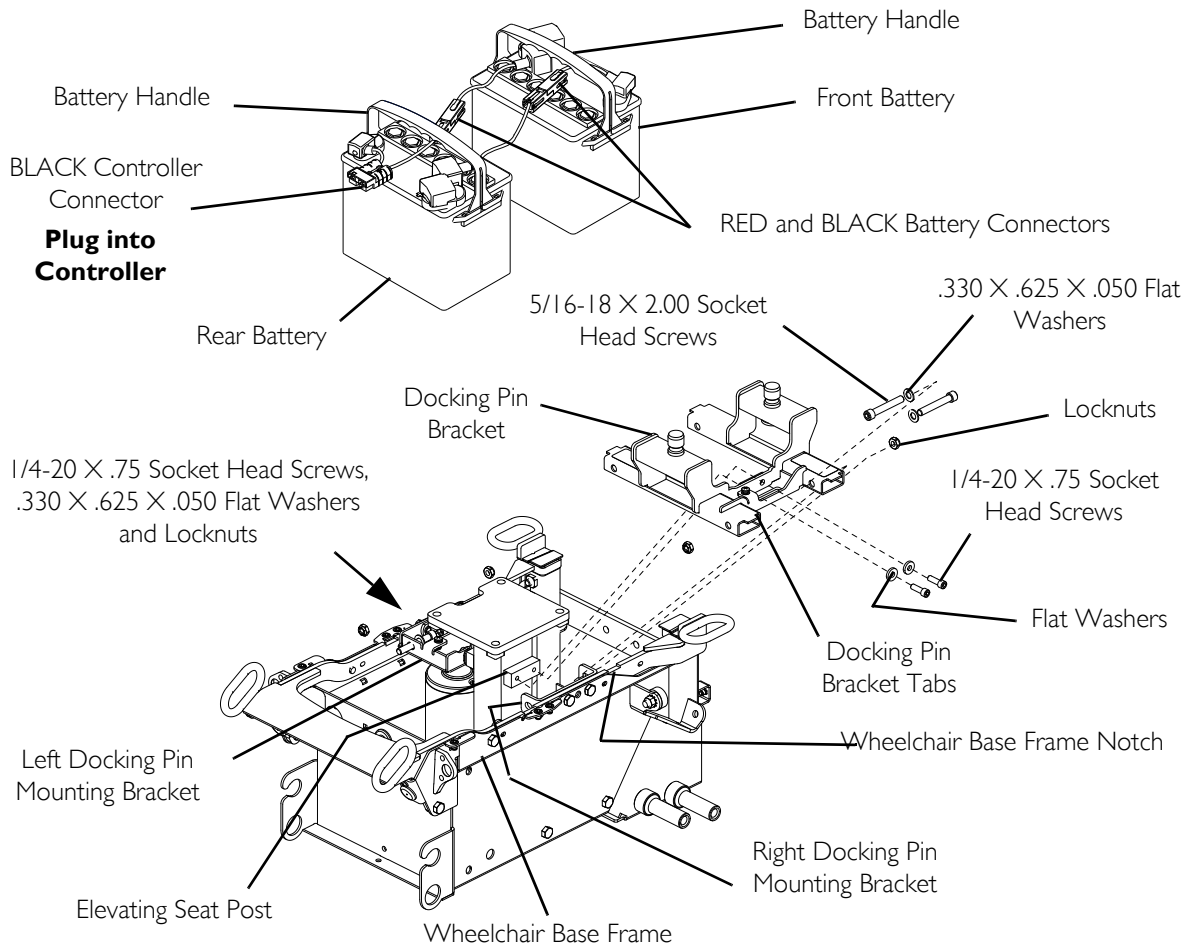

FIGURE 12.4 Installing/Removing the Batteries on TDX Spree with TRRO

Removing/Installing the Elevating Seat Assembly

NOTE: For this procedure, refer to FIGURE 12.5 on page 57.

NOTE: It is strongly recommended that two assistants lift the seat assembly when performing this procedure.

Removing

1. Disconnect the joystick. Refer to Disconnecting/Connecting the Joysticks on page 40.
2. Remove the seat cushion.
3. Remove the two socket screws securing the seat pan to the seat frame.
4. Remove the seat pan from the seat frame.
5. Remove the four mounting bolts and locknuts securing the seat assembly to the actuator post.
6. Remove the seat assembly from the actuator post and set aside.

Installing

1. Position the seat assembly onto the actuator post.
2. Using four mounting bolts and locknuts, secure the seat assembly to the actuator post. Securely tighten.
3. Position the seat pan onto the seat frame as shown.
4. Using the two socket screws, secure the seat pan to the seat frame.
5. Install the seat cushion.
6. Connect the joystick. Refer to Disconnecting/Connecting the Joysticks on page 40.

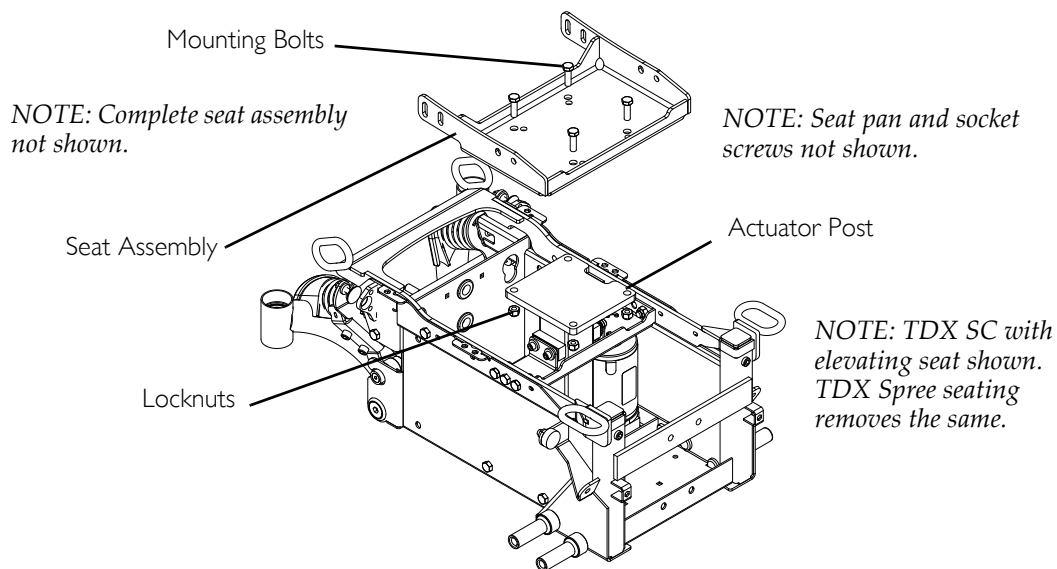

FIGURE 12.5 Removing/Installing the Elevating Seat Assembly

Replacing the Batteries

NOTE: Refer to Disconnecting Battery Cables on page 58.

Disconnecting/Connecting Battery Cables

Disconnecting Battery Cables

WARNING

The use of rubber gloves is recommended when working with batteries.

NEVER allow any of your tools and/or battery cables to contact both battery terminals at the same time. An electrical short may occur and serious personal injury or damage may occur.

NOTE: For this procedure, refer to FIGURE 12.6 on page 60.

1. Remove the batteries. Refer to Removing/Installing the Batteries on page 51.
2. Cut the tie-wrap that secures the battery terminal cap in place (Detail “B” of FIGURE 12.6).
3. Slide terminal caps up onto the battery cables (FIGURE 12.6).
4. Disconnect POSITIVE (+) battery cable from the POSITIVE (+) battery terminal (FIGURE 12.6).
5. Disconnect NEGATIVE (-) battery cable from NEGATIVE (-) battery terminal (FIGURE 12.6).

Connecting Battery Cables

⚠ WARNING

NEVER allow any of your tools and/or battery cables to contact both battery terminals at the same time. An electrical short may occur and serious personal injury or damage may occur.

Connect same color connectors to each other (**RED to RED, BLACK to BLACK**).

DO NOT remove fuse or mounting hardware from **POSITIVE (+)** battery cable mounting screw. To replace the fuse, obtain and replace battery harness with fuse.

The **POSITIVE (+)** battery cable **MUST** connect to the **POSITIVE (+)** battery terminal, otherwise serious damage will occur to the electrical system.

The use of rubber gloves is recommended when working with batteries.

Battery terminal configuration as shown in Detail “A” of **FIGURE 12.6** **MUST** be used. Batteries that have the terminal configuration reversed **MUST NOT** be used - otherwise serious injury or damage may occur.

Install protective caps on **POSITIVE (+)** and **NEGATIVE (-)** terminals.

All battery terminal covers (two on the front battery and two on the rear battery) **MUST** be installed prior to use.

CAUTION

When connecting the battery cables to the battery, the battery cables **MUST** be connected to the battery terminals, as shown in Detail “A” of **FIGURE 12.6** (depending on battery type), otherwise damage to the battery cable may result when installing battery terminal caps.

NOTE: For this procedure, refer to FIGURE 12.6 on page 60.

1. Secure the battery cables to the battery terminals as described below. Securely tighten. Refer to Detail “A” of FIGURE 12.6:
 - A. Secure **NEGATIVE (-)** battery cable to the **NEGATIVE (-)** battery terminal using the mounting screw and the locknut.
 - B. Secure the **POSITIVE (+)** battery cable to the **POSITIVE (+)** battery terminal using the L-bracket with mounting screw and the locknut.
2. Verify all battery cables are correctly installed and securely tightened.
3. Slide terminal caps down battery cables and onto battery terminals.
4. Secure each terminal cap in place with a tie-wrap [use tie-wraps 11-1/2-inches long] (Detail “B” of FIGURE 12.6).
5. Position the batteries into the wheelchair. Refer to [Removing/Installing the Batteries](#) on page 51.

NOTE: New batteries MUST be fully charged before using, otherwise the life of the batteries will be reduced.

6. If necessary, charge the battery. Refer to [Charging Batteries](#) on page 61.

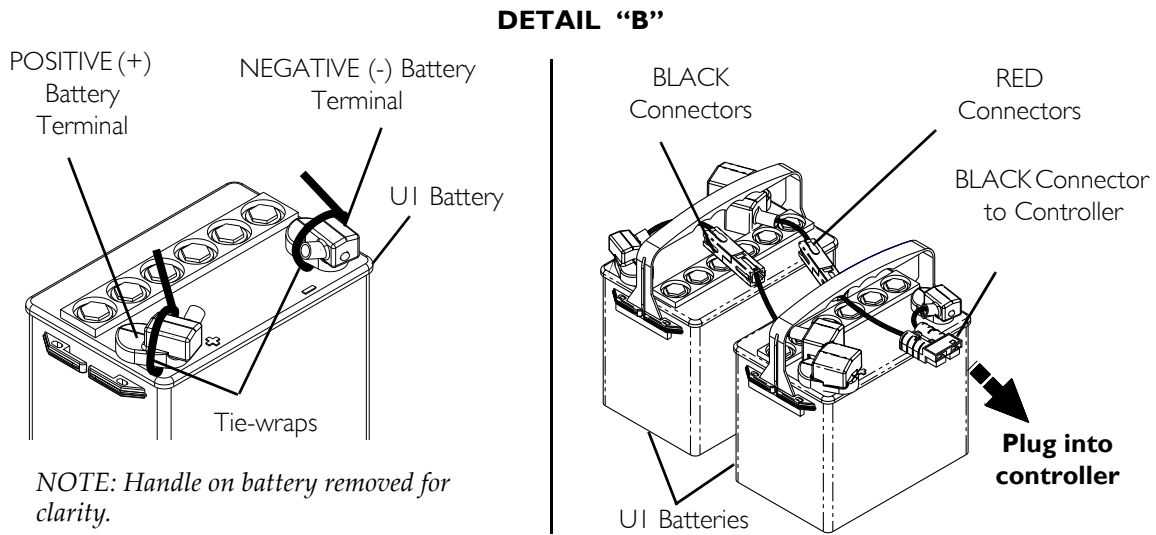
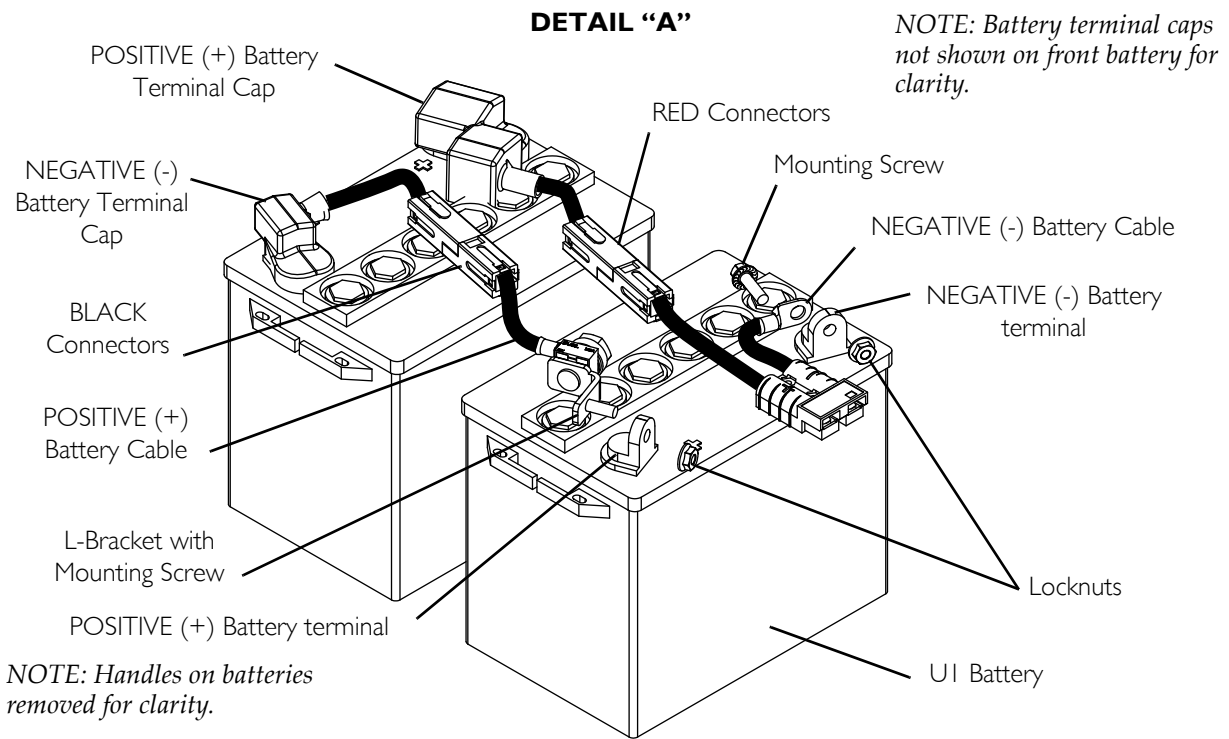

FIGURE 12.6 Disconnecting/Connecting Battery Cables

When to Charge Batteries

SPJ+, SPJ+ w/PSS and SPJ+ w/ACC Joysticks

NOTE: For this procedure, refer to FIGURE 12.7.

The Information Gauge Display located on the front of the joystick housing, it provides the state-of-battery charge, including notification of when the battery requires charging. It also provides the following information to the user on the status of the wheelchair:

- A. GREEN LEDs are lit, indicating well charged batteries.
- B. AMBER LEDs are lit, indicating batteries are moderately charged. Recharge batteries before taking a long trip.
- C. RED LEDs are lit, indicating batteries are running out of charge. Recharge batteries as soon as possible.

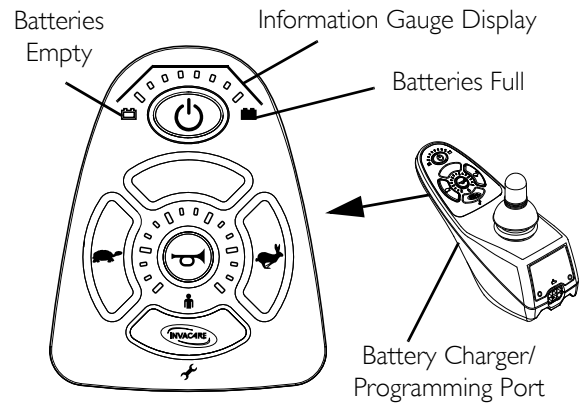

FIGURE 12.7 SPJ+, SPJ+ w/PSS and SPJ+ w/ACC Joysticks

MPJ+ Joystick

NOTE: For this procedure, refer to FIGURE 12.8 on page 61.

The far right side of the display screen is the Battery Gauge Display (BGD). It provides information on the remaining charge in the batteries.

At full charge, solid blocks fill in all ten segments between E (Empty) and F (Full). As the battery becomes discharged, the segments will progressively disappear a bar at a time until no segments appear between E and F. At this level the user should charge the batteries as soon as possible.

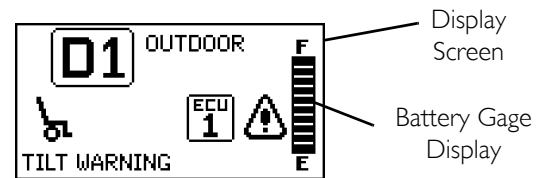

FIGURE 12.8 MPJ+ Joystick

Charging Batteries

⚠ WARNING

NEVER attempt to recharge the batteries by attaching cables directly to the battery terminals or clamps. **ALWAYS** use the recharging plug located on the back of the joystick.

DO NOT attempt to recharge the batteries and operate the power wheelchair at the same time.

During use and charging, unsealed batteries will vent hydrogen gas which is explosive in the right concentration with air.

CAUTION

Always charge new batteries before initial use or battery life will be reduced.

NOTE: For this procedure, refer to FIGURE 12.9 on page 62.

NOTE: New batteries MUST be fully charged prior to initial use of the wheelchair.

NOTE: As a general rule, batteries should be recharged daily to assure the longest possible life and minimize the required charging time. Plan to recharge the batteries when it is anticipated the wheelchair will not be used for a long period of time.

The range per battery charge using recommended batteries should be approximately 5 to 9 hours of typical operation. Extensive use on inclines may substantially reduce per charge mileage.

Description and Use of Battery Chargers

The charger automatically reduces the charge from an initially high rate to a zero reading at a fully charged condition. If left unattended, the charger should automatically shut-off when full charge is obtained.

There are some basic concepts which will help you understand this automatic process. They are:

The amount of electrical current drawn within a given time to charge a battery is called the “charge rate”. If, due to usage, the charge stored in the battery is low, the charge rate is high, as indicated by the GREEN light on the charger. Initially, the GREEN light will stay illuminated for a short period of time followed by a longer period of off time. As a charge builds up, the charge rate is reduced, and the GREEN light will stay illuminated for a longer period of time followed by a shorter off time.

⚠ WARNING

NEVER leave the charger unattended when the breaker has tripped. A fault condition exists. Unplug and discontinue using immediately. Contact an Invacare dealer.

NOTE: If performing the charging procedures independently, READ and CAREFULLY follow the individual instructions for each charger (supplied or purchased).

NOTE: If charging instructions are not supplied, consult a qualified service technician for proper procedures.

Required Items:

TOOL	QUANTITY	COMMENTS
Battery Charger	1	Supplied
Extension Cord	1	Not Supplied

1. Attach the battery charger connector to the charger port on the joystick.
2. Plug the charger’s AC power cord, or extension, into the grounded 120 VAC wall outlet.
3. Wait until charging is complete.

NOTE: Allow eight hours for normal charging. Larger batteries (greater than 55 ampere-hours) or severely discharged batteries may require up to sixteen hours to be properly charged and equalized.

NOTE: It is advantageous to recharge frequently rather than only when necessary. In fact, a battery’s life is extended if the charge level is maintained well above a low condition.

NOTE: If the batteries need to be charged more often or take longer to charge than normal, they may need to be replaced. Contact an Invacare dealer for service.

SPJ+, SPJ+ w/PSS and SPJ+ w/ACC Joysticks

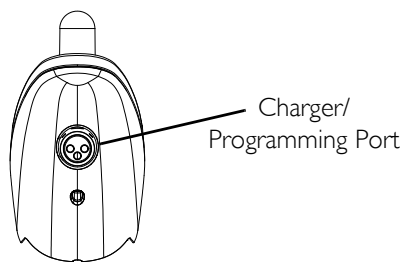

MPJ+ Joystick

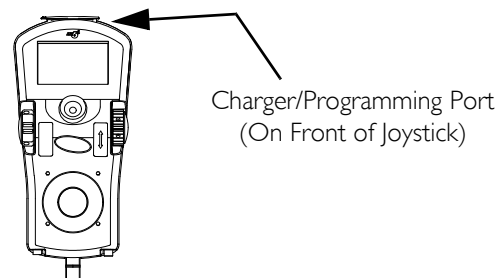

FIGURE 12.9 Charging Batteries

Cleaning Battery Terminals

WARNING

Most batteries are not sold with instructions. However, warnings are frequently noted on the cell caps. Read them carefully.

DO NOT allow the liquid in the battery to come in contact with skin, clothes or other possessions. It is a form of acid and harmful or damaging burns may result. Should the liquid touch your skin, wash the area IMMEDIATELY and thoroughly with cool water. In serious cases or if eye contact is made, seek medical attention IMMEDIATELY.

1. Examine battery terminals for corrosion.
2. Verify the plastic caps are in place over battery cell holes.
3. Clean terminals by using a battery cleaning tool, wire brush, or medium grade sand paper.

NOTE: Upon completion, areas should be shiny, not dull.

4. Carefully dust off all metal particles.

SECTION 13—TRANSPORT READY PACKAGE (TRRO)

NOTE: The information in this section is for wheelchairs ordered with the transport ready package ONLY.

⚠ WARNING

Contact Invacare Corporation (800-333-6900) with any questions about using this wheelchair for seating in a motor vehicle.

When feasible, wheelchair occupants should transfer into the vehicle seat and use the OEM (Original Equipment Manufacturer) vehicle-installed restraint system.

This wheelchair has been dynamically tested in a forward-facing mode with the specified crash test dummy restrained by **BOTH** pelvic and upper-torso belt(s) (shoulder belts), and that **BOTH** pelvic and upper-torso belt(s) should be used to reduce the possibility of head and chest impacts with vehicle components.

Use **ONLY** Wheelchair Tie-down and Occupant Restraint Systems (WTORS) which meet the requirements of the SAE (Society of Automotive Engineers) J2249 Recommended Practice during travel in a motor vehicle.

This wheelchair has been tested for seating in a motor vehicle with the factory installed wheelchair seating system **ONLY**.

This wheelchair **MUST** be in a forward facing position during travel in a motor vehicle.

This wheelchair is equipped and has been dynamically tested to rely on **WHEELCHAIR-ANCHORED** pelvic belts. If desired, **VEHICLE-ANCHORED** pelvic belts may be used.

IT IS STRONGLY RECOMMENDED THAT BOTH PELVIC AND UPPER-TORSO BELT(S) BE USED TO REDUCE THE RISK OF INJURY.

To reduce the potential of injury to vehicle occupants, wheelchair-mounted accessories, including but not limited to IV poles, trays, respiratory equipment, backpacks, and other personal items should be removed and secured separately.

Postural supports, positioning devices, and/or strap(s) should not be relied on for occupant restraint. These items may be used **IN ADDITION TO** the wheelchair-anchored or vehicle-anchored belts.

Seat angle is factory set at time of shipment. Adjustments to the wheelchair may void WC 19 compliance. To maintain compliance, refer to wheelchair service manual before making any adjustments.

DO NOT alter or substitute wheelchair frame parts, components, or seating systems.

A sudden stop and/or collision may structurally damage your wheelchair. Wheelchairs involved in such incidents should be replaced.

Spill proof batteries, such as “gel cells”, should be installed on wheelchairs to be used during travel in a motor vehicle.

⚠ WARNING

Transport ready packages are not retrofittable to existing models and are not field serviceable.

Only use the transport brackets included with TRRO and TRBKTS for the purposes described in this manual.

About Transport Ready Packages

TRRO includes four factory-installed transport brackets and a wheelchair anchored pelvic belt. TRRO has been crash-tested in accordance with ANSI/RESNA WC Vol 1 Section 19 Frontal Impact Test requirements for wheelchairs with a 130 lb crash test dummy, which corresponds to a person with a weight of 125 to 165 lbs. for Junior seat sizes or a 168 lb crash dummy, which corresponds to a person with a weight of 165 to 300 lbs. for Adult seat sizes.

TRBKTS includes four factory-installed wheelchair transport brackets. TRBKTS has not been crash-tested in accordance with WC 19. Use these transport brackets only to secure an unoccupied wheelchair during transport.

As of this date, the U.S. Department of Transportation has not approved any tie-down systems for transportation of a user while in a wheelchair, in a moving vehicle of any type. It is Invacare's position that users of wheelchairs should be transferred into appropriate seating in vehicles for transportation and use be made of the restraints made available by the auto industry. Invacare cannot and does not recommend any wheelchair transportation systems.

Compliance Information

This wheelchair conforms with the requirements of the ANSI/RESNA WC/Vol. 1 - Section 19.

NOTE: ANSI = American National Standards Institute, RESNA= Rehabilitation Engineering and Assistive Technology Society of North America.

This wheelchair has been dynamically tested in a forward-facing mode with a 130 lb crash test dummy, which corresponds to a person with a weight of 125 to 165 lbs. for Junior seat sizes or a 168 lb crash dummy, which corresponds to a person with a weight of 165 to 300 lbs. for Adult seat sizes, restrained by Both pelvic and upper-torso belts in accordance with ansi/resna wc Vol 1 Section 19. Both pelvic and upper-torso belts should be used to reduce the possibility of head and chest impacts with vehicle components.

Specifications

MODEL	MOTOR	WHEELCHAIR WEIGHT LIMIT	
		ADULT	JUNIOR
TDX SC	2 Pole	Up to 250 pounds	N/A
TDX SPREE	2 Pole	N/A	Up to 165 pounds

Securing the Wheelchair to the Vehicle

Positioning the Wheelchair in the Vehicle

⚠ WARNING

This wheelchair must be in a forward facing position during travel in a motor vehicle.

The recommended clear zones for wheelchair seated occupants restrained by **BOTH** pelvic and upper-torso belt(s) and **ONLY** by a pelvic belt are shown in the diagrams and described below.

Frontal Clear Zones (FCZ) need to be **LARGER** when upper-torso belt(s) are **NOT** used.

The rear clear zone of 16-inches is measured from the rearmost point on an occupant's head.

The frontal clear zone is measured from the frontmost point on an occupant's head and is 26-inches with pelvic and upper-torso belt(s) and 37-inches with **ONLY** a pelvic belt.

The frontal clear zone may not be achievable for wheelchair-seated drivers.

The estimated seated height (HHT) from the ground or floor to the top of the wheelchair-seated occupant's head ranges from approximately 47-inches for a small adult female to about 61-inches for a tall adult male.

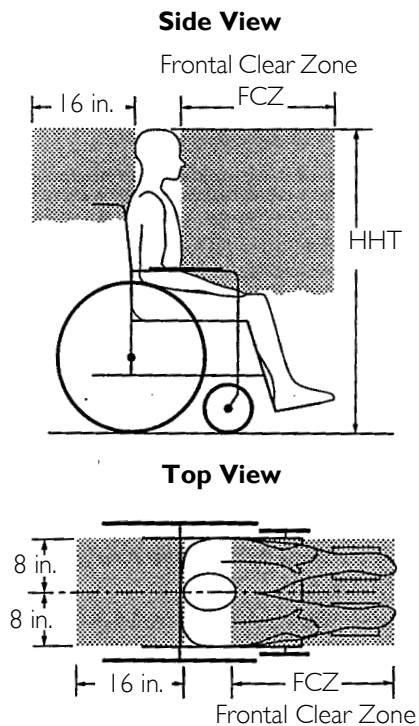

Securement Points

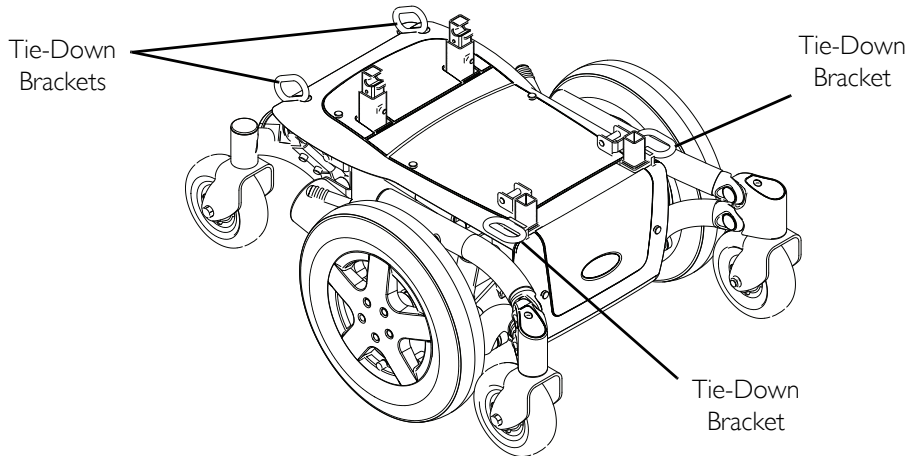

FIGURE 13.1 Securement Points

Securing the Wheelchair

This wheelchair is to be used only with Wheelchair Tie-down and Occupant Restraint Systems (WTORS) that have been installed in accordance with the manufacturer's instructions and SAE J2249.

NOTE: A copy of SAE J2249 Wheelchair Tie-down and Occupant Restraint Systems (WTORS) for use in Motor Vehicles can be obtained from: SAE International, 400 Commonwealth Drive, Warrendale, PA 15096-0001, (877) 606-7232 or (724) 776-4970.

Attach WTORS to the tie-down brackets in accordance with the manufacturer's instructions and SAE J2249.

Securing the Occupant

Wheelchair-Anchored Belts

⚠ WARNING

The pelvic belt that is provided by Invacare has been tested for use in a motor vehicle on this wheelchair ONLY. DO NOT replace the pelvic belt with a different style pelvic belt.

NOTE: For this procedure, refer to FIGURE 13.2 on page 69.

The wheelchair has been provided with a pelvic belt which meets the requirements of ANSI/RESNA W/C 19.

The pelvic belt, provided by Invacare, has been designed to accommodate use on either side of the vehicle. If necessary, follow the instructions below to reverse the orientation of the pelvic belt to accommodate the vehicle-anchored upper-torso belt.

1. Install the pelvic belt pin (Detail "A" of FIGURE 13.2) into the large end of the slot in the belt mounting bracket (Detail "B"). Rotate downward and forward until it snaps into place into the small end of the slot.

NOTE: Note the position of the male end of the belt when installing the pelvic belt onto the belt mounting brackets. The male end of the pelvic belt (Detail "A" of FIGURE 13.2) has a pin which is used to secure the vehicle-anchored upper-torso belt.

2. Repeat STEP 1 for the opposite belt mounting bracket.
3. Install the vehicle-anchored upper-torso belt onto the pin on the male end of the pelvic belt.

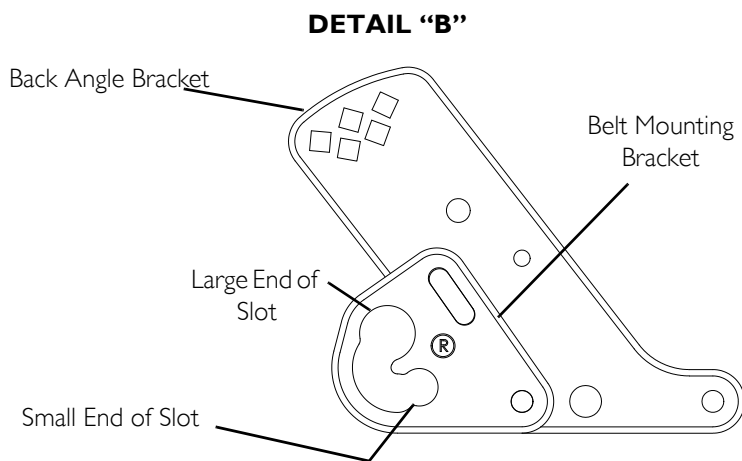
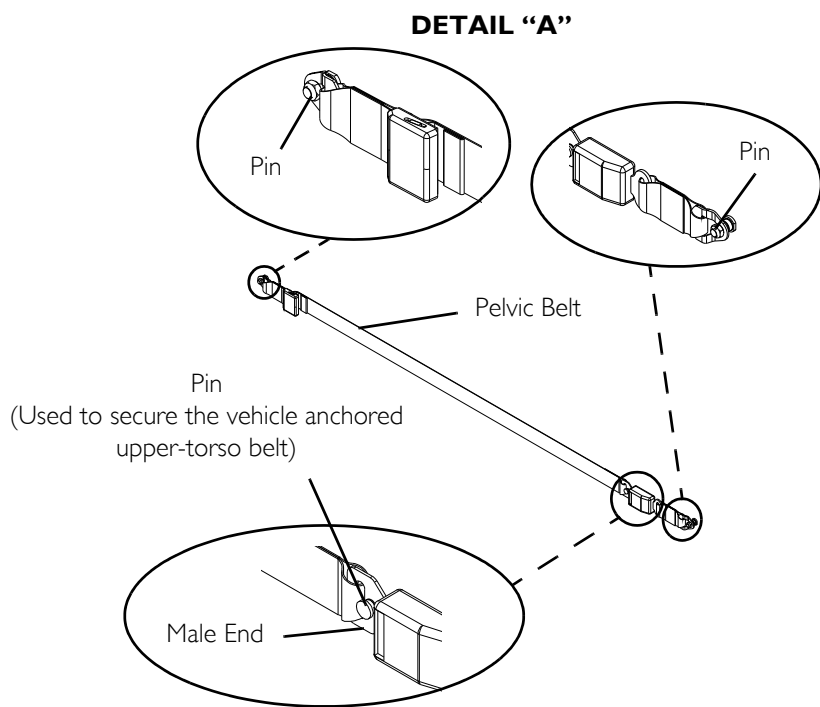

FIGURE 13.2 Wheelchair-Anchored Belts

Vehicle-Anchored Belts

NOTE: For this procedure, refer to FIGURE 13.3.

With regard to accommodating the use and fit of vehicle-anchored belts, this wheelchair has an overall rating of:

- TDX SC - A
- TDX SPREE - A

This rating is scored as follows:

RATING	DESCRIPTION
A	Excellent
B	Good
C	Fair
D	Poor

The test for Lateral Stability Displacement for Point (P) is shown in FIGURE 13.3. The average test result for point (P) is:

- TDX SC Adult - 0.47-inches (11.9 mm)
- TDX SPREE - 0.53-inches (13.0 mm)

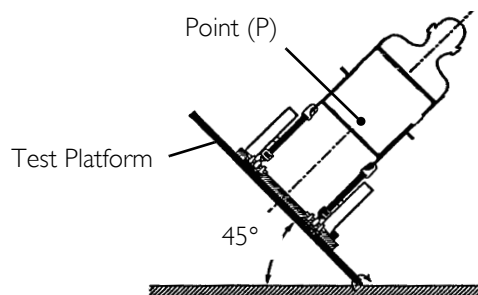

NOTE: Rear view of the wheelchair and human surrogate secured on test platform and tilted to 45°.

FIGURE 13.3 Vehicle-Anchored Belts

Seating System

⚠ WARNING

This wheelchair has been tested for seating in a motor vehicle with the factory installed seating system **ONLY**.

Ensure that the factory installed seating system is secured to the wheelchair frame before operation. Refer to the seating system owner's manual.

Positioning Belts

⚠ WARNING

The angle of the pelvic belt should be within the preferred zone of 45 to 75 degrees to the horizontal **OR** within the optional zone of 30 to 45 degrees to the horizontal.

Steeper side-view pelvic belt angles are especially important if the pelvic belt is intended to be used for postural support in addition to occupant restraint in a frontal crash. Steeper angles will reduce the tendency for a vertical gap to develop between the user and the belt due to compliance of seat cushions and belt movement, thereby reducing the tendency for the user to slip under the belt and for the belt to ride up on the soft abdomen during normal use.

Steeper belt angles also reduce the tendency for upper-torso belts to pull the pelvic belt onto the abdomen during frontal impact loading.

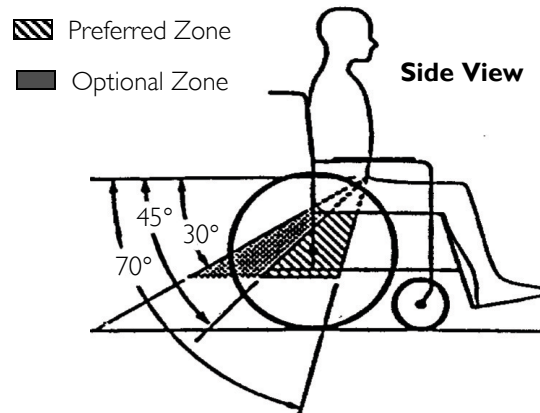

NOTA: Para este procedimiento, consulte la FIGURE 13.4.

1. The pelvic belt should be worn low across the front of the pelvis.
2. Position the upper-torso belt(s) over the shoulders.
3. The belt(s) should not be held away from the body by wheelchair components or parts, including but not limited to wheelchair armrests or wheels. Refer to FIGURE 13.4 for proper and improper positioning of the belts.
4. Ensure the belt(s) are not twisted.
5. Adjust belts as firmly as possible, being mindful of user comfort.

DO POSITION BELT INSIDE OF ARMRESTS, WHEELS, ETC.



DO NOT POSITION BELT OUTSIDE OF ARMRESTS, WHEELS, ETC.



FIGURE 13.4 Positioning Belts

NOTES

NOTES

GLOBAL LIMITED WARRANTY (EXCLUDING CANADA)

PLEASE NOTE: THE WARRANTY BELOW HAS BEEN DRAFTED TO COMPLY WITH FEDERAL LAW APPLICABLE TO PRODUCTS MANUFACTURED AFTER JULY 4, 1975.

This warranty is extended only to the original purchaser who purchases this product within any country excluding **CANADA** when new and unused from Invacare or a dealer. This warranty is not extended to any other person or entity and is not transferable or assignable to any subsequent purchaser or owner. Coverage under this warranty will end upon any such subsequent sale or other transfer of title to any other person. For product purchased in Canada, please refer to the Canada Limited Warranty.

This warranty gives you specific legal rights and you may also have other legal rights which vary from state to state.

Invacare warrants the base frame to be free from defects in materials and workmanship for a period of five (5) years from the date of purchase from Invacare or a dealer, with a copy of the seller's invoice required for coverage under this warranty. Invacare warrants all electronics and electrical components (excluding batteries), motors, powered seating actuators and gearboxes to be free from defects in materials and workmanship for a period of one (1) year from the date of purchase from Invacare or a dealer, with a copy of the seller's invoice required for coverage under this warranty. Invacare warrants all batteries to be free from defects in materials and workmanship for a period of six (6) months from the date of purchase from Invacare or a dealer, with a copy of the seller's invoice required for coverage under this warranty. Invacare warrants all remaining components (excluding all upholstered materials, padded materials, tires and wheels) to be free from defects in materials and workmanship for a period of one (1) year from the date of purchase from Invacare or a dealer, with a copy of the seller's invoice required for coverage under this warranty. If within such warranty periods any such product component shall be proven to be defective, the product component shall be repaired or replaced, at Invacare's option with refurbished or new parts. This warranty does not include any labor or shipping charges incurred in replacement part installation or repair of any such product. Product repairs shall not extend this warranty - coverage for repaired product shall end when this limited warranty terminates. Invacare's sole obligation and your exclusive remedy under this warranty shall be limited to such repair and/or replacement.

For warranty service, please contact the dealer from whom you purchased your Invacare product. In the event you do not receive satisfactory warranty service, please write directly to Invacare at the address on the bottom of the back cover. Provide dealer's name address, date of purchase, indicate nature of the defect and, if the product is serialized, indicate the serial number. Do not return products to our factory without our prior consent.

LIMITATIONS AND EXCLUSIONS: THE FOREGOING WARRANTY SHALL NOT APPLY TO SERIAL NUMBERED PRODUCTS IF THE SERIAL NUMBER HAS BEEN REMOVED OR DEFACED, PRODUCTS SUBJECT TO NEGLIGENCE, ACCIDENT, IMPROPER OPERATION, MAINTENANCE OR STORAGE, COMMERCIAL OR INSTITUTIONAL USE, PRODUCTS MODIFIED WITHOUT INVACARE'S EXPRESS WRITTEN CONSENT (INCLUDING, BUT NOT LIMITED TO, MODIFICATION THROUGH THE USE OF UNAUTHORIZED PARTS OR ATTACHMENTS); PRODUCTS DAMAGED BY REASON OF REPAIRS MADE TO ANY COMPONENT WITHOUT THE SPECIFIC CONSENT OF INVACARE, OR TO A PRODUCT DAMAGED BY CIRCUMSTANCES BEYOND INVACARE'S CONTROL, AND SUCH EVALUATION WILL BE SOLELY DETERMINED BY INVACARE. THE WARRANTY SHALL NOT APPLY TO PROBLEMS ARISING FROM NORMAL WEAR AND TEAR OR FAILURE TO ADHERE TO THE PRODUCT INSTRUCTIONS. A CHANGE IN OPERATING NOISE, PARTICULARLY RELATIVE TO MOTORS AND GEARBOXES DOES NOT CONSTITUTE A FAILURE OR DEFECT AND WILL NOT BE REPAIRED; ALL DEVICES WILL EXHIBIT CHANGES IN OPERATING NOISE DUE TO AGING. THE FOREGOING EXPRESS WARRANTY IS EXCLUSIVE AND IN LIEU OF ANY OTHER WARRANTIES WHATSOEVER, WHETHER EXPRESS OR IMPLIED, INCLUDING THE IMPLIED WARRANTIES OF MERCHANTABILITY AND FITNESS FOR A PARTICULAR PURPOSE, AND THE SOLE REMEDY FOR VIOLATIONS OF ANY WARRANTY WHATSOEVER, SHALL BE LIMITED TO REPAIR OR REPLACEMENT OF THE DEFECTIVE PRODUCT PURSUANT TO THE TERMS CONTAINED HEREIN. THE APPLICATION OF ANY IMPLIED WARRANTY WHATSOEVER SHALL NOT EXTEND BEYOND THE DURATION OF THE EXPRESS WARRANTY PROVIDED HEREIN AND INVACARE SHALL NOT BE LIABLE FOR ANY CONSEQUENTIAL OR INCIDENTAL DAMAGES WHATSOEVER; SOME STATES DO NOT ALLOW THE EXCLUSION OR LIMITATION OF INCIDENTAL OR CONSEQUENTIAL DAMAGE, OR LIMITATION OF HOW LONG AN IMPLIED WARRANTY LASTS, SO THE ABOVE EXCLUSION AND LIMITATION MAY NOT BE APPLICABLE. THIS WARRANTY SHALL BE EXTENDED TO COMPLY WITH STATE/PROVINCIAL LAWS AND REQUIREMENTS.

CANADA LIMITED WARRANTY

This warranty is extended only to the original purchaser who purchases this product within Canada when new and unused from Invacare or a dealer. This warranty is not extended to any other person or entity and is not transferable or assignable to any subsequent purchaser or owner. Coverage under this warranty will end upon any such subsequent sale or other transfer of title to any other person.

This warranty gives you specific legal rights and you may also have other legal rights which vary from state to state.

Invacare warrants the base frame to be free from defects in materials and workmanship for a period of five (5) years from the date of purchase from Invacare or a dealer, with a copy of the seller's invoice required for coverage under this warranty. Invacare warrants all electronics and electrical components (excluding batteries), powered seating actuators, 2-pole motors and gearboxes to be free from defects in materials and workmanship for a period of two (2) years from the date of purchase from Invacare or a dealer, with a copy of the seller's invoice required for coverage under this warranty. Invacare warrants all batteries to be free from defects in materials and workmanship for a period of six (6) months from the date of purchase from Invacare or a dealer, with a copy of the seller's invoice required for coverage under this warranty. Invacare warrants all remaining components (excluding all upholstered materials, padded materials, tires and wheels) to be free from defects in materials and workmanship for a period of one (1) year from the date of purchase from Invacare or a dealer, with a copy of the seller's invoice required for coverage under this warranty. If within such warranty periods any such product component shall be proven to be defective, the product component shall be repaired or replaced, at Invacare's option with refurbished or new parts. This warranty does not include any labor or shipping charges incurred in replacement part installation or repair of any such product. Product repairs shall not extend this warranty - coverage for repaired product shall end when this limited warranty terminates. Invacare's sole obligation and your exclusive remedy under this warranty shall be limited to such repair and/or replacement

For warranty service, please contact the dealer from whom you purchased your Invacare product. In the event you do not receive satisfactory warranty service, please write directly to Invacare at the address on the bottom of the back cover. Provide dealer's name address, date of purchase, indicate nature of the defect and, if the product is serialized, indicate the serial number. Do not return products to our factory without our prior consent.

LIMITATIONS AND EXCLUSIONS: THE FOREGOING WARRANTY SHALL NOT APPLY TO SERIAL NUMBERED PRODUCTS IF THE SERIAL NUMBER HAS BEEN REMOVED OR DEFACED, PRODUCTS SUBJECT TO NEGLIGENCE, ACCIDENT, IMPROPER OPERATION, MAINTENANCE OR STORAGE, COMMERCIAL OR INSTITUTIONAL USE, PRODUCTS MODIFIED WITHOUT INVACARE'S EXPRESS WRITTEN CONSENT (INCLUDING, BUT NOT LIMITED TO, MODIFICATION THROUGH THE USE OF UNAUTHORIZED PARTS OR ATTACHMENTS); PRODUCTS DAMAGED BY REASON OF REPAIRS MADE TO ANY COMPONENT WITHOUT THE SPECIFIC CONSENT OF INVACARE, OR TO A PRODUCT DAMAGED BY CIRCUMSTANCES BEYOND INVACARE'S CONTROL, AND SUCH EVALUATION WILL BE SOLELY DETERMINED BY INVACARE. THE WARRANTY SHALL NOT APPLY TO PROBLEMS ARISING FROM NORMAL WEAR AND TEAR OR FAILURE TO ADHERE TO THE PRODUCT INSTRUCTIONS. A CHANGE IN OPERATING NOISE, PARTICULARLY RELATIVE TO MOTORS AND GEARBOXES DOES NOT CONSTITUTE A FAILURE OR DEFECT AND WILL NOT BE REPAIRED; ALL DEVICES WILL EXHIBIT CHANGES IN OPERATING NOISE DUE TO AGING. THE FOREGOING EXPRESS WARRANTY IS EXCLUSIVE AND IN LIEU OF ANY OTHER WARRANTIES WHATSOEVER, WHETHER EXPRESS OR IMPLIED, INCLUDING THE IMPLIED WARRANTIES OF MERCHANTABILITY AND FITNESS FOR A PARTICULAR PURPOSE, AND THE SOLE REMEDY FOR VIOLATIONS OF ANY WARRANTY WHATSOEVER, SHALL BE LIMITED TO REPAIR OR REPLACEMENT OF THE DEFECTIVE PRODUCT PURSUANT TO THE TERMS CONTAINED HEREIN. THE APPLICATION OF ANY IMPLIED WARRANTY WHATSOEVER SHALL NOT EXTEND BEYOND THE DURATION OF THE EXPRESS WARRANTY PROVIDED HEREIN AND INVACARE SHALL NOT BE LIABLE FOR ANY CONSEQUENTIAL OR INCIDENTAL DAMAGES WHATSOEVER; SOME STATES DO NOT ALLOW THE EXCLUSION OR LIMITATION OF INCIDENTAL OR CONSEQUENTIAL DAMAGE, OR LIMITATION OF HOW LONG AN IMPLIED WARRANTY LASTS, SO THE ABOVE EXCLUSION AND LIMITATION MAY NOT BE APPLICABLE. THIS WARRANTY SHALL BE EXTENDED TO COMPLY WITH STATE/PROVINCIAL LAWS AND REQUIREMENTS.



Yes, you can.

Invacare Corporation www.invacare.com

USA
One Invacare Way
Elyria, Ohio USA
44036-2125
800-333-6900

Canada
570 Matheson Blvd E Unit 8
Mississauga Ontario
L4Z 4G4 Canada
800-668-5324

All rights reserved. Trademarks are identified by the symbols [™] and [®]. All trademarks are owned by or licensed to Invacare Corporation or its subsidiaries unless otherwise noted.

Loctite is a registered trademark of Loctite Corporation.

© 2009 Invacare Corporation

Part No 1149267

Rev D - 9/09

