

Invacare® HomeFill® Oxygen System

Model IOH200

en **Compressor
User Manual**

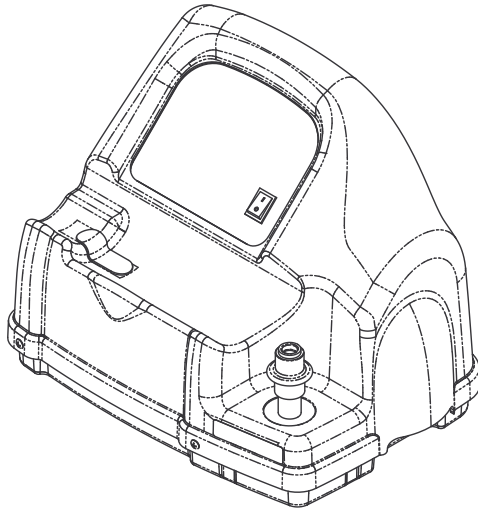

This manual **MUST** be given to the user of the product.
BEFORE using this product, read this manual and save for future reference.



Yes, you can.®

©2018 Invacare Corporation

All rights reserved. Republication, duplication or modification in whole or in part is prohibited without prior written permission from Invacare. Trademarks are identified by ™ and ®. All trademarks are owned by or licensed to Invacare Corporation or its subsidiaries unless otherwise noted.

Platinum is a registered trademark in the U.S.A., Europe and Australia.

Making Life's Experiences Possible is a registered trademark in the U.S.A.

3-in-1 oil is a registered trademark of American Home Products Corporation.

WD-40 is a registered trademark of the WD-40 Company.

Updated versions of this manual are available on www.invacare.com.

Contents

1 General	4
1.1 Symbols	4
1.2 Intended Use	5
2 Safety	7
2.1 General Guidelines	7
2.2 Label Locations	10
2.3 Dealer Information	11
2.4 Double-Insulated Products	11
2.5 EMC Information	11
3 Setup	13
3.1 Unpacking	13
3.2 Compressor Initial Setup Checklist	13
3.3 Choosing a Location	14
3.4 Transporting the Compressor	14
3.5 Installing the Power Cord	15
3.6 Connecting the Compressor to the Concentrator	16
4 Usage	17
4.1 Compressor Operation Checklist	17
4.2 Cylinder Prefill Inspection	17
4.3 Connecting the Cylinder to the Compressor	19
4.4 Disconnecting the Cylinder from the Compressor	20
4.5 Turning the Compressor On and Off	21
5 Maintenance	23
5.1 Maintenance Info	23
5.2 Wear and Tear	23
5.3 Service Life	23
5.4 Cleaning the Compressor Filter	24
5.5 Cleaning the Cabinet	24
5.6 Replacing the Fuse	25
6 After Use	26
6.1 Disposal	26

7 Troubleshooting	27
7.1 Indicator Lights	27
7.2 Troubleshooting	29
8 Technical Data	32
8.1 Technical Description	32
8.2 Specifications	32
9 Warranty	34
9.1 Limited Warranty	34

1 General

1.1 Symbols

Symbols in the Manual

Signal words are used in this manual and apply to hazards or unsafe practices which could result in personal injury or property damage. See the information below for definitions of the signal words.



DANGER!

– Danger indicates an imminently hazardous situation which, if not avoided, will result in death or serious injury.



WARNING!

– Warning indicates a potentially hazardous situation which, if not avoided, could result in death or serious injury.



CAUTION!

– Caution indicates a potentially hazardous situation which, if not avoided, may result in property damage or minor injury or both.



IMPORTANT

– Indicates a hazardous situation that could result in damage to property if it is not avoided.



Gives useful tips, recommendations and information for efficient, trouble-free use.

Symbols on the Product

The following symbols are found on the compressor, compressor packaging or the oxygen cylinder.



Read the Manual (Compressor)



Read the Manual (Cylinder)



Electrical Hazard



Alternating Current



Type BF equipment — Applied Parts



Power switch “ON”



Power switch “OFF”



DO NOT smoke



No Open Flame



Class II, Double Insulation. Refer to 2.4 *Double-Insulated Products*, page 11.



Keep dry in transport or storage and during use



Fuse



Oxidizer



Transport and Storage Temperature



Transport and Storage Humidity



Recycle this product. Refer to 6.1 *Disposal*, page 26.

1.2 Intended Use



WARNING!

- The use of this device is limited to refilling a specific patient's own oxygen cylinders. The designated cylinders **MUST** be used **ONLY** by the specific oxygen patient and are not to be distributed to any other individual for any purpose.
- No other use of this device is indicated.



WARNING!

Risk of Death, Injury or Damage

- The Invacare HomeFill compressor was designed to be used only with Invacare oxygen concentrators. Use with other types of devices may cause injury, death or property damage.
- **DO NOT** use the Invacare HomeFill compressor with anything other than an Invacare oxygen concentrator.
 - Use only with specially designed Invacare oxygen concentrators that are HomeFill compatible.

To determine if your oxygen concentrator is HomeFill compatible, examine the lower right corner of the rear of the oxygen concentrator **Ⓐ** for an outlet fitting **Ⓑ**.

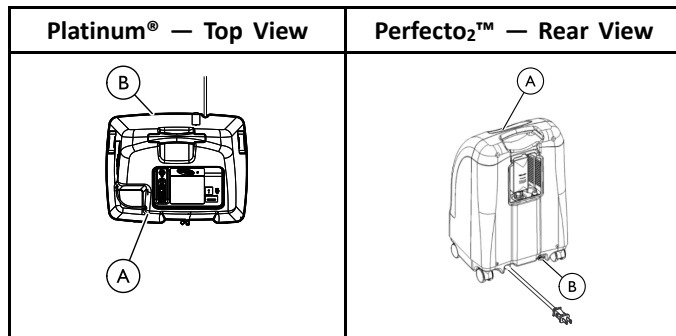

The intended use of an Invacare HomeFill compressor is an accessory device to an Invacare oxygen concentrator that enables the patient to refill custom portable oxygen cylinders for personal use.

This product is intended for single patient use in the indoor homecare environment only and is not to be used for bulk cylinder refilling.

No specific product knowledge or training is required, other than what is contained in this manual, to operate the product.

It is not intended for supplying oxygen therapy during refilling.

This product is intended to be used by or under adult supervision only after reading and understanding the instructions and warnings of this user manual.

2 Safety

2.1 General Guidelines

**DANGER!****Risk Of Death, Injury, Or Damage**

Improper use of the product may cause death, injury or damage. This section contains important information for the safe operation and use of this product.

- DO NOT use this product or any available optional equipment without first completely reading and understanding these instructions and any additional instructional material such as user manuals, service manuals or instruction sheets supplied with this product or optional equipment.
- If you are unable to understand the warnings, cautions or instructions, contact a healthcare professional, dealer or technical personnel before attempting to use this equipment.
- Check ALL external components and carton for damage. In case of damage, or if the product is not working correctly, contact a technician or Invacare for repair.
- In order to ensure the safe installation, assembly and operation of the HomeFill Compressor these instructions MUST be followed.
- THE INFORMATION IN THIS DOCUMENT IS SUBJECT TO CHANGE WITHOUT NOTICE.

**DANGER!****Risk Of Death, Injury, Or Damage From Fire**

Textiles, oil or petroleum substances, grease, greasy substances and other combustibles are easily ignited and burn with great intensity in oxygen enriched air and when in contact with oxygen under pressure. To avoid fire, death, injury or damage:

- DO NOT SMOKE while using this device.
- DO NOT use near OPEN FLAME or IGNITION SOURCES.
- DO NOT use any lubricants on the compressor unless recommended by Invacare.
- NO SMOKING signs should be prominently displayed.
- Avoid creation of any spark near oxygen equipment. This includes sparks from static electricity created by any type of friction.
- Keep all matches, lighted cigarettes or other sources of ignition out of the room in which this compressor is located and away from where oxygen is being delivered.
- Keep the oxygen tubing, cord, and compressor out from under such items as blankets, bed coverings, chair cushions, clothing, and away from heated or hot surfaces including space heaters, stoves, and similar electrical appliances.



DANGER!

Risk Of Death, Injury, Or Damage From Fire

Textiles, oil or petroleum substances, grease, greasy substances and other combustibles are easily ignited and burn with great intensity in oxygen enriched air and when in contact with oxygen under pressure. To avoid fire, death, injury or damage:

- DO NOT allow oil from your hands or other sources to come into contact with the compressor coupling or cylinder fittings. These substances may become flammable in the presence of oxygen and cause injury. Avoid touching the cylinder fitting whenever possible. Example of items to avoid are hand creams or lotions, cooking oils, suntan oils or sunblocks and similar oily products. If you use these types of products Invacare suggests you wash your hands prior to using the HomeFill unit. If the cylinder fitting should come in contact with such substances it should be cleaned off with a damp cloth prior to connecting it to the compressor.
- NEVER oil or lubricate the compressor coupler or cylinder fittings. NEVER use any penetrating oil or lubricant such as WD-40® or 3-in-1 Oil®. If connection difficulty is experienced verify that the cylinder fitting is being inserted straight down into the compressor coupler. If continued difficulty is experienced contact your supplier for assistance.



DANGER!

Risk of Electric Shock

This unit contains moving and high pressure components. There are no user serviceable parts inside the cover. To avoid electric shock, injury or death:

- DO NOT remove the cover.
- Refer servicing to qualified personnel.



WARNING!

Risk of Serious Injury or Damage

Use of non-Invacare accessories may result in serious injury or damage.

- Invacare products are specifically designed and manufactured for use in conjunction with Invacare accessories. Accessories designed by other manufacturers have not been tested by Invacare and are not recommended for use with Invacare products.
- DO NOT use non-Invacare accessories.
- To obtain Invacare accessories, contact Invacare by phone or at www.invacare.com



WARNING!

Risk of injury or damage

Blocking the air flow into and out of the compressor may cause injury or damage.

- NEVER block the air openings of the product or place it on a soft surface, such as a bed or couch, where the air opening may be blocked.
- Keep the openings free from lint, hair and similar foreign items.

**WARNING!****Risk of Injury or Damage**

A damaged product may malfunction and cause injury or damage. To avoid injury or damage:

- DO NOT get the compressor wet.
- If the compressor has a damaged cord or plug, if it is not working properly, if it has been dropped or damaged, or submersed in water, call a qualified technician for examination and repair.

**WARNING!**

- DO NOT use the compressor outdoors. Indoor use only.
- If any leakage of the oxygen cylinder is detected DO NOT attempt to use the cylinder. Turn the flow selector knob on the regulator to “Off”. If leakage persists, place the cylinder outdoors and notify your Home Health Care Provider or Service Representative of this condition.
- Children should ALWAYS be supervised around the HomeFill unit. When used with the HomeFill table or similar elevated support surfaces, a child could pull over any such table causing the unit to fall. Failure to observe this warning may result in personal injury or product damage.

**WARNING!****Risk of injury or damage**

The HomeFill is equipped with a high pressure relief valve to ensure the user’s safety. When activated, this safety feature will make an extremely loud noise. To avoid injury or damage:

- If this noise occurs, turn the unit Off and contact your Home Health Care Provider or Service Representative.

**WARNING!****Risk of injury or damage**

If improperly positioned and secured, the power cord and interconnect hose can cause injury due to tripping and falling. Product damage may also occur.

- The power cord and interconnect hose MUST be routed and secured properly.
- Avoid positioning power cords across areas of high traffic.
- Before moving or repositioning either the compressor or concentrator, ALWAYS disconnect the AC power cords and the interconnect hose between the compressor and concentrator.

**CAUTION!**

Federal (statutory) law restricts this device sale to or on the order of a medical practitioner licensed by a governmental agency where he/she practices.

- ONLY a licensed medical practitioner may order the purchase or use of this device.

2.2 Label Locations

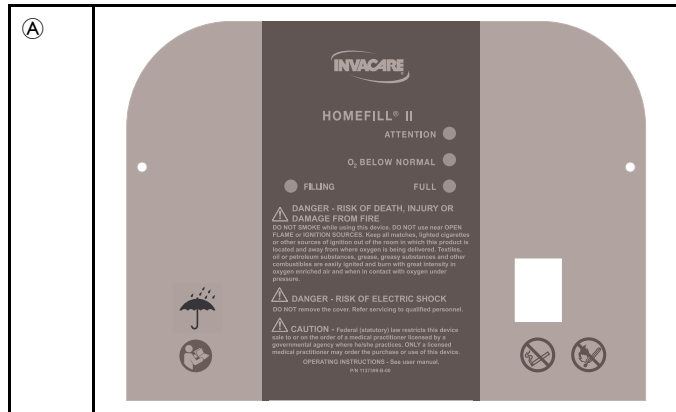
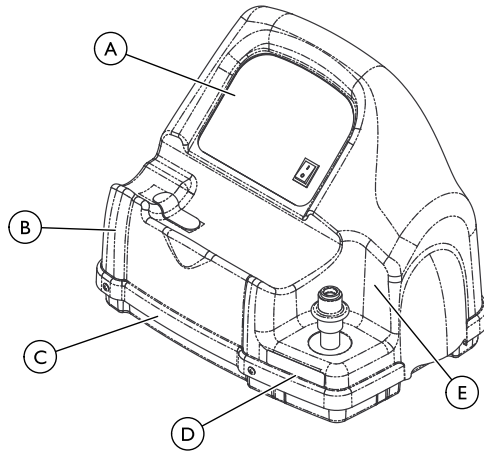

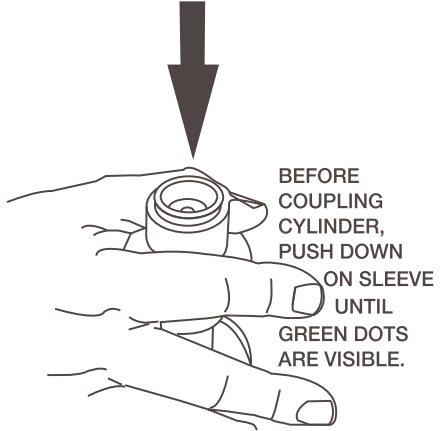
B	<p>⚠ DANGER Risk of Death, Injury or Damage from Fire Keep all connections free of oil and grease to avoid violent ignition. See user manual before cleaning. 1075220-D-00</p>
C	<p>⚠ DANGER Risk of Electric Shock DO NOT REMOVE UNIT COVER This unit contains moving and high pressure components. Manufacturer Service Only. 1075221-C-01</p>
D	<p>⚠ DANGER Risk of Death, Injury or Damage from Fire Keep all connections free of oil and grease to avoid violent ignition. See user manual before cleaning. Never oil or lubricate coupling. Cylinders filled on this unit MUST be labeled "Contents of this cylinder are the product of an oxygen concentrator." 1075238-D-00</p>
E	 <p>BEFORE COUPLING CYLINDER, PUSH DOWN ON SLEEVE UNTIL GREEN DOTS ARE VISIBLE.</p>

2.3 Dealer Information



Invacare recommends leaving a full cylinder of oxygen with the patient after setting up the HomeFill compressor.

Before leaving a HomeFill Compressor with a user, the following checklist **MUST** be completed:

- Make sure the pressure test on cylinder has not expired.
- Instruct the user on the safe operation of the concentrator and review all warnings.
- Instruct the user on the safe operation of the HomeFill compressor and review all warnings.
- Leave a full cylinder of oxygen with the user.
- Leave a copy of all warnings and filling instructions with the user.

2.4 Double-Insulated Products



CAUTION!

– DO NOT unplug the power cord by pulling on the cord. To unplug, grasp the plug not the cord, otherwise damage may occur.

In a double-insulated product, two systems of insulation are provided instead of grounding. No grounding means is required on a double-insulated product, nor is a means for grounding to be added to the product. A double-insulated product is marked with the words “DOUBLE INSULATION” or “DOUBLE INSULATED” or the symbol:



2.5 EMC Information



WARNING!

Risk of Injury or Damage

To reduce the risk of injury or product damage from interference with wireless equipment:

- Keep the compressor at least 9.8 ft (3.0 m) away from wireless communication equipment such as wireless home network devices, mobile phones, cordless phones and base stations, walkie-talkies, etc.

Medical Electrical Equipment needs to be installed and used according to the EMC information in this manual.

This equipment has been tested and found to comply with EMC limits specified by IEC/EN 60601-1-2 for Type BF equipment. These limits are determined to provide reasonable protection against electromagnetic interference in a typical home healthcare environment. This equipment is not intended for use in a professional healthcare environment.

Portable and mobile RF communications equipment can affect the operation of this equipment. The compressor may be stacked on top on an Invacare HomeFill compatible oxygen concentrator during setup. The compressor operation should be observed to verify normal cylinder filling in either situation.

Other devices may experience interference from even the low levels of electromagnetic emissions permitted by the above standard. To determine if the emissions from the compressor are causing the interference, turn the compressor Off. If the interference with the other

device operation stops, then the compressor is causing the interference. In such rare cases, interference may be reduced or corrected by one of the following measures:

- Reposition, relocate, or increase the separation between the devices.
- Connect either line powered device to a different electrical power circuit.

Contact Invacare for any additional EMC information or EMC tables for the device environment.

3 Setup

3.1 Unpacking

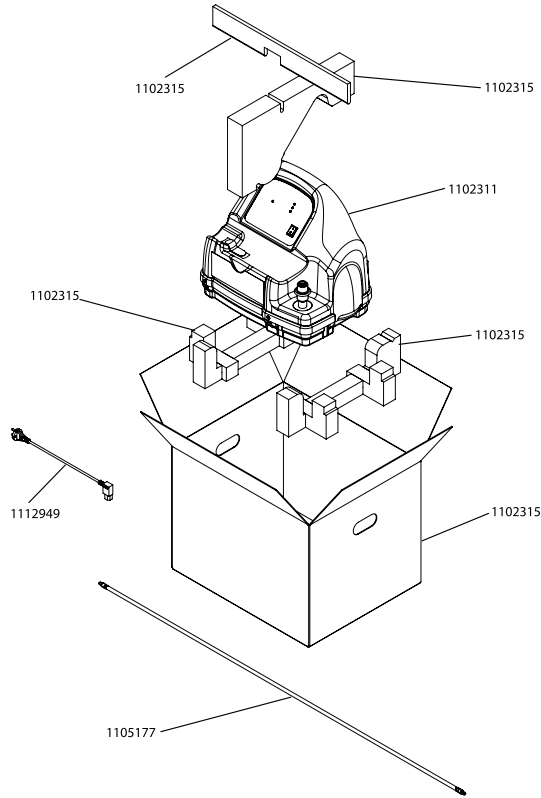

PART NUMBER	DESCRIPTION
1102311	Compressor Assembly
1102315	Packaging Assembly
1105177	Supply Line Assembly
1112949	Power Cord
1100873	User Manual (not shown)

1. Check for any obvious damage to the carton or its contents. If damage is evident, notify the carrier, or your local dealer.
2. Remove all loose packing from the carton.
3. Carefully remove all of the components from the carton.



Unless the compressor is to be used IMMEDIATELY, leave the compressor in its packaging for storage until use of the compressor is required.

3.2 Compressor Initial Setup Checklist



Dealers ONLY — Refer to 2.3 *Dealer Information*, page 11 before performing this procedure.



Users ONLY — Contact your Invacare dealer or Invacare for assistance with the setup procedure and to report unexpected operation or events.

Before operating the HomeFill Compressor for the first time, complete the following checklist:

- Choose a location for the compressor.
- Transport the compressor to the desired location.
- Connect the power cord to the compressor.

- ❑ Connect the compressor to the concentrator.

3.3 Choosing a Location



DANGER!

Risk Of Death, Injury, Or Damage From Fire

Textiles, oil or petroleum substances, grease, greasy substances and other combustibles are easily ignited and burn with great intensity in oxygen enriched air and when in contact with oxygen under pressure. To avoid fire, death, injury or damage:

- DO NOT SMOKE while using this device.
- DO NOT use near OPEN FLAME or IGNITION SOURCES.
- DO NOT use any lubricants on the compressor unless recommended by Invacare.
- NO SMOKING signs should be prominently displayed.
- Avoid creation of any spark near oxygen equipment. This includes sparks from static electricity created by any type of friction.
- Keep all matches, lighted cigarettes or other sources of ignition out of the room in which this compressor is located and away from where oxygen is being delivered.
- Keep the oxygen tubing, cord, and compressor out from under such items as blankets, bed coverings, chair cushions, clothing, and away from heated or hot surfaces including space heaters, stoves, and similar electrical appliances.

The compressor should be at least three inches away from walls, draperies or furniture to ensure sufficient air flow.

Avoid placing the compressor next to heaters, radiators or hot air registers.

DO NOT use in a closet.

The compressor should sit on a hard flat stable surface, such as a table or the Ready Rack.

3.4 Transporting the Compressor



WARNING!

- NEVER transport a compressor with a cylinder connected to or stored on the compressor, otherwise injury or damage can occur.



CAUTION!

- When transporting the compressor, be careful not to bump the compressor or the connectors into obstacles. Otherwise, damage to the compressor may occur.

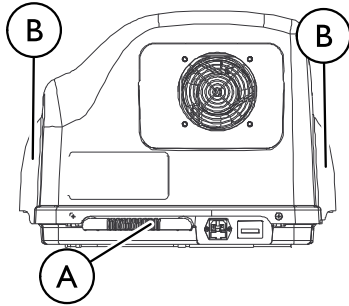

1. There are two methods to safely transport the compressor:

- One Hand - Grasp the hand grip **A** at the bottom rear of the compressor.
- Two Hands - Grasp the hand grips **B** on the sides of compressor.

3.5 Installing the Power Cord

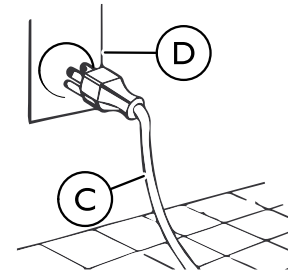
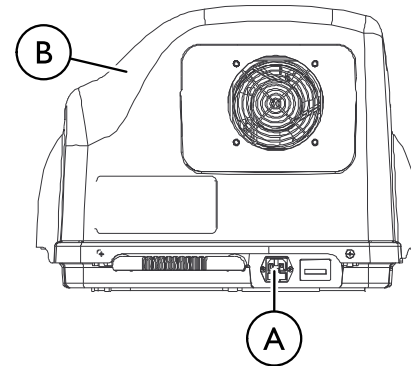

This product may come with a polarized plug (one blade is wider than the other). As a safety feature, this plug will fit in a polarized outlet only one way. If the plug does not fit fully in the outlet, reverse the plug. If it still does not fit, contact a qualified electrician. **DO NOT** attempt to defeat this safety feature.

1. Choose a proper location. Refer to 3.3 *Choosing a Location*, page 14.
2. Make sure the power switch is in the Off (O) position.
3. Plug the power cord into the electric connector (A) in the back of the compressor (B).
4. Plug the opposite end of the power cord (C) into the wall outlet (D).
5. Leave a minimum of 3" (7.6 cm) clearance to the power cord ends for disconnection access.

 The power inlet acts as the mains disconnection device to remove all power to the unit when the line cord is disconnected.

1. Insert one end of the interconnect hose (C) into the outlet fitting (B) on the back of the concentrator (A).
2. Insert the opposite end of the interconnect hose into the inlet fitting (D) on the side of the compressor.

 The metal tabs (E) on the concentrator outlet fitting and the compressor inlet fitting will pop out with an audible "click" when the end of the interconnect hose is properly installed.

3. Loop any excess interconnect hose and secure to the back of the concentrator with the fastening straps.

3.6 Connecting the Compressor to the Concentrator

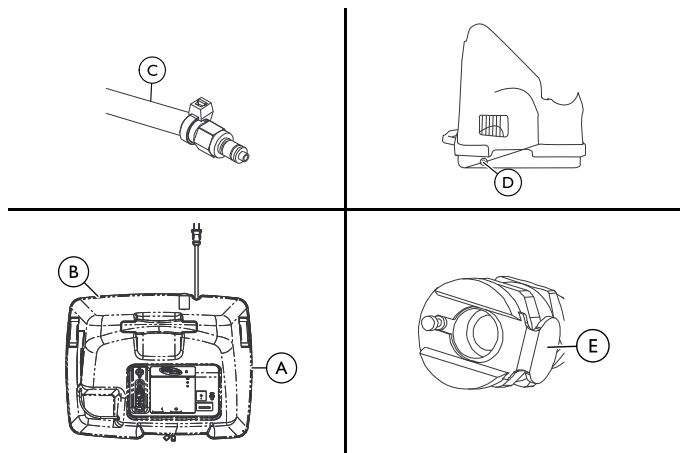

4 Usage

4.1 Compressor Operation Checklist

Each time the HomeFill Compressor is used to fill a cylinder, complete the following checklist:

- Ensure the concentrator has been On for at least thirty minutes. Refer to the concentrator User Manual.
- Perform the prefill inspection on the cylinder.
- Connect the cylinder to the compressor.
- Push the compressor power switch to the On (I) position.
- Examine the indicator lights on the control panel.
- Disconnect and remove the full cylinder.
- Push the compressor power switch to the Off (O) position.
- If filling another cylinder, repeat this checklist.

4.2 Cylinder Prefill Inspection



WARNING!

- ONLY use cylinders that have the Invacare HomeFill connection and HomeFill label.
- All cylinders MUST be inspected before attempting to fill. Otherwise, injury or damage may occur.

To identify a HomeFill compatible cylinder **(A)**, look for a black stripe **(B)** in the green area **(C)** on the top of the cylinder and look for the HomeFill label **(D)**.



The Hydrostatic Testing Date

Aluminum cylinders **MUST** undergo testing every five years.



WARNING!

– DO NOT fill cylinders that have not been tested in the past five years. Otherwise, serious personal injury may result. Contact your dealer for replacement.

External Examination

1. Examine the outside of the cylinder for the following conditions, and replace the cylinder if they exist:
 - Dents or dings
 - Arc burns
 - Oil or grease
 - Any other signs of damage that might cause a cylinder to be unacceptable or unsafe for use.
2. Examine the cylinder for evidence of fire or thermal damage. Evidence includes charring or blistering of the paint, or other protective coating or heat sensitive indicator. If fire or thermal damage is found, replace the cylinder.
3. Inspect the cylinder/regulator assembly for the following and replace if found:
 - Debris, oil or grease
 - Noticeable signs of damage
 - Signs of corrosion inside the valve
 - Signs of excessive heat or fire damage

4.3 Connecting the Cylinder to the Compressor



WARNING!

– NEVER use tools of any kind to connect/disconnect the cylinder and the compressor. Otherwise, severe injury and/or damage may occur.



WARNING!

– DO NOT drop oxygen cylinders. Use two hands when handling/transporting oxygen cylinders. Otherwise, injury or damage may occur.
– DO NOT use a liquid leak detector to test for leaks.

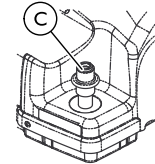
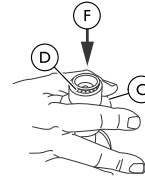
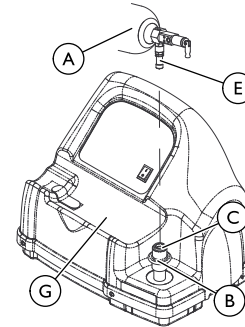

Fillport covers not shown for clarity.

1. Examine the cylinder gauge. If the cylinder pressure is less than 1500 psig, proceed to STEP 2.



For location of the cylinder gauge, refer to the cylinder's manual.

If the cylinder pressure is **greater** than 1500 psig, DO NOT attempt to top off this cylinder. It may not fill.

2. Set the regulator flow dial on the cylinder (A) to Off. Refer to the cylinder's manual.

3. Remove the cylinder and connector fillport covers (if present).
4. Momentarily push DOWN on the outer ring (sleeve) ⑥ of the connector fillport ③ until GREEN dots ④ are visible to reset the connector.

i If the outer ring (sleeve) is in the UP position (GREEN dots not visible), the connector fillport will not be able to accept the cylinder fillport ⑤. Pushing DOWN ⑥ momentarily will reset the connector fillport (GREEN dots visible) to accept the cylinder fillport.

5. Grasp the cylinder in the area behind the cylinder fillport.
6. Position the cylinder in the compressor cradle ⑦.
7. Align the cylinder fillport with the connector fillport.
8. Pull UP on the outer ring (sleeve) of the connector fillport while pushing DOWN on the cylinder to couple the cylinder fillport into the connector fillport.

i The cylinder is properly connected when an audible “click” is heard.

4.4 Disconnecting the Cylinder from the Compressor

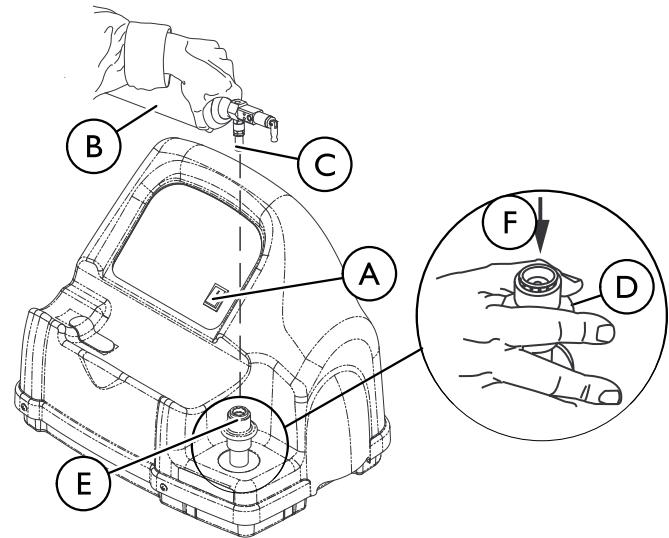

WARNING!

– NEVER use tools of any kind to connect/disconnect the cylinder and the compressor. Otherwise, severe injury and/or damage may occur.

1. Press the compressor power switch ① to the Off (O) position.
2. Grasp the cylinder ② in the area behind the cylinder fillport ③.

3. With the other hand, grasp the outer ring (sleeve) of the connector fillport ⑤ and push DOWN ⑥.
4. Lift up on the cylinder to remove from the connector fillport.
5. When the cylinder fillport is disconnected from the connector fillport, release the outer ring (sleeve) of the connector fillport and use two hands to remove the cylinder from the compressor cradle.

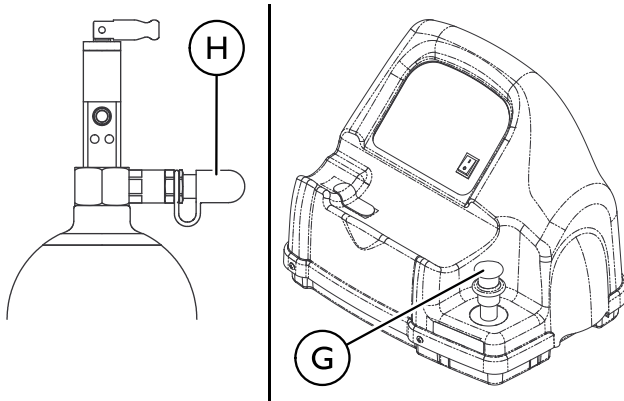

WARNING!

– The fillport cover on the connector fillport and the cylinder fillport **MUST** be replaced after filling and whenever not in use. If either of the fillport covers are missing contact your healthcare provider before using.

6. Place the fillport covers onto the connector fillport ③ and cylinder fillport ④.



When using the post valve type cylinder, attach an oxygen regulator per manufacturers instructions.

7. Examine the cylinder gauge to ensure cylinder is full (needle pointing into GREEN area). If the cylinder is not full, perform the following:
 - a. Repeat 4.3 *Connecting the Cylinder to the Compressor*, page 19.
 - b. If cylinder is not full after second attempt to fill, contact the provider.

4.5 Turning the Compressor On and Off

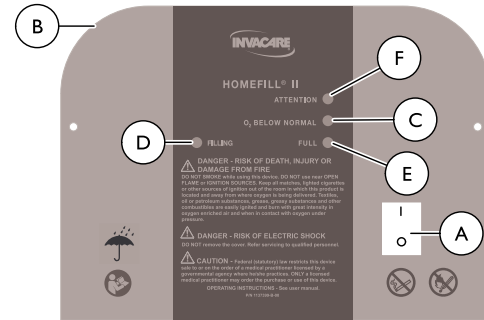



1. Make sure the concentrator is On. Refer to the concentrator User Manual.



 The maximum oxygen concentrator flow rate for patient use is listed in the table below. Otherwise, the oxygen level to the compressor will be <90% and the compressor will not fill the cylinder.

Invacare Oxygen Concentrator	Maximum Output Flow for Patient Use
Platinum 5 and XL	3 L/min
Platinum 10	5 L/min
Perfecto ₂	3 L/min

 Patients with a higher prescribed flow should not refill a cylinder while receiving supplemental oxygen treatment from the oxygen concentrator.

2. Set the concentrator flow rate to the patient to 3 L/min or less for Platinum 5, XL, and Perfecto₂ and 5 L/min or less for Platinum 10. Refer to the concentrator User Manual.
3. Make sure the cylinder is connected to the compressor. Refer to 4.3 *Connecting the Cylinder to the Compressor*, page 19.
4. Push the power switch  on the control panel to the On (I) position.

5. Examine the control panel . The following sequence of events should occur:

- a. 0-3 minutes - The O₂ Below Normal (YELLOW) light  will be lit while the compressor warms up.
- b. After three minutes - The FILLING (GREEN) light  will be on while the cylinder is filling.
- c. The FULL (GREEN) light  will be on when the cylinder is finished filling. Proceed to STEP 6.

 The O₂ BELOW NORMAL (YELLOW) light may come on if the oxygen level from the concentrator has not yet reached or drops below 90%. The compressor will begin or resume filling when the oxygen level reaches 90%. If light does not go Off within 10 minutes, refer to 7.2 *Troubleshooting*, page 29.

If the ATTENTION (RED) light and audible alarm  are on refer to 7.2 *Troubleshooting*, page 29.

6. Remove the full cylinder. Refer to 4.4 *Disconnecting the Cylinder from the Compressor*, page 20.
7. Push the power switch to the Off (O) position.

5 Maintenance

5.1 Maintenance Info

**DANGER!****Risk of Electric Shock**

This unit contains moving and high pressure components. There are no user serviceable parts inside the cover. To avoid electric shock, injury or death:

- DO NOT remove the cover.
- Refer servicing to qualified personnel.

**WARNING!**

– Only the parts and procedures identified in this section are to be performed by the operator. All other parts and procedures are to be performed by a qualified technician.

5.2 Wear and Tear

Invacare reserves the right to ask for any item back that has an alleged defect in workmanship. See the warranty in this manual for specific warranty information.

Refer to the procedures in this User Manual for proper preventative maintenance schedule and use of the product.

This is just a general guideline and does not include items damaged due to abuse and misuse. Useful life is dependent upon many factors.

Normal wear and tear items and components for this product are listed below.

1100873-M

- All types of filters
- All types of tubing

5.3 Service Life

The expected service life of this product is 5 years or 5000 hours of operation when used in accordance with the safety instructions, maintenance intervals and correct use, stated in this manual. The effective service life can vary according to frequency and intensity of use. Maintenance should be done at least every week.

5.4 Cleaning the Compressor Filter



WARNING!

- Push the power switch to the Off (O) position and unplug the compressor before cleaning.
- DO NOT operate the compressor without the filter installed.



CAUTION!

- DO NOT unplug by pulling on cord. To unplug, grasp the plug not the cord, otherwise damage may occur.



All compressors have one filter on the back of the cabinet.

Perform this procedure at least once a week.

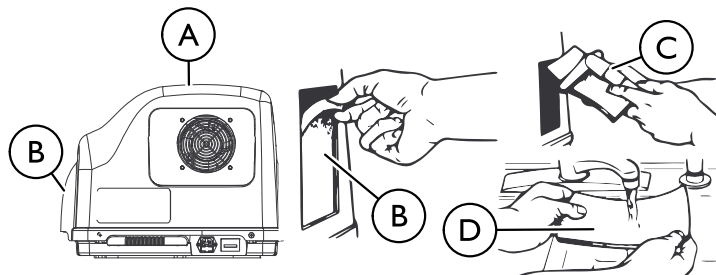

1. Unplug the compressor (A). Grasp the plug not the cord.
2. Remove the filter (B).

3. Clean the filter with a vacuum cleaner (C) or wash in warm soapy water and rinse thoroughly (D).
4. Dry the filter thoroughly before reinstallation.

5.5 Cleaning the Cabinet



DANGER!

Risk of Electric Shock

This unit contains moving and high pressure components. There are no user serviceable parts inside the cover. To avoid electric shock, injury or death:

- DO NOT remove the cover.
- Refer servicing to qualified personnel.

1. Clean the cabinet with a mild household cleaner and non-abrasive cloth or sponge.

5.6 Replacing the Fuse

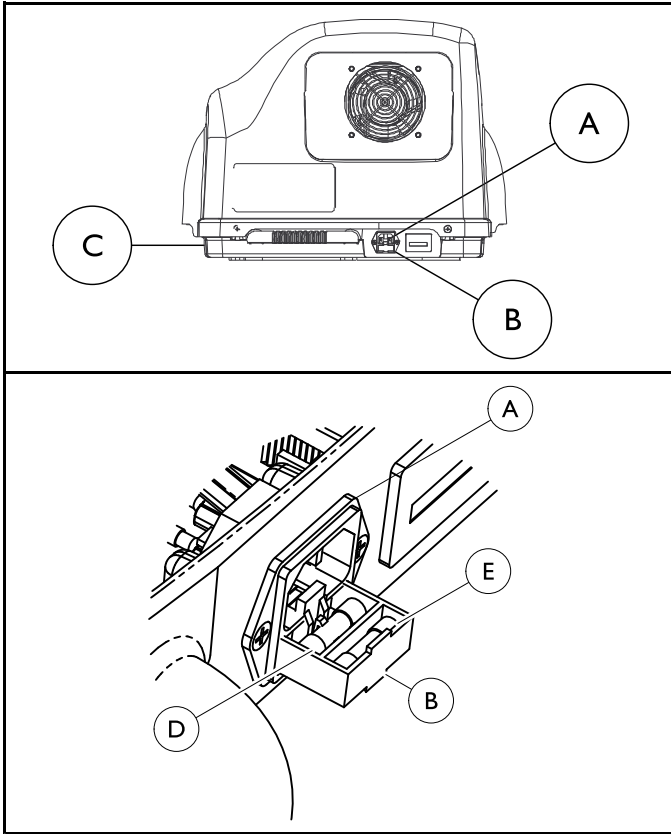

1. Unplug the power cord from the electrical outlet.
2. Remove the power cord from the power inlet (A) on the compressor base (C).
3. Pull out the fuse drawer (B) at the bottom of the power inlet.
4. Using a fuse puller or a small flat blade screw driver, remove the front fuse inside the fuse drawer and discard.



The fuse drawer contains space for two fuses. The front location is for the operational fuse. The unit is supplied with the front fuse only. The rear location is for an optional spare fuse. When replacing the front fuse, ensure that there is a spare fuse with the same type and rating in the fuse drawer.

5. Install replacement fuse in front fuse (D) slot.



Use a 5 mm x 20 mm, time lag, low breaking capacity, 250V, 2 Amp, IEC 60127 style only (Invacare part number 1099820).

6. Push fuse drawer back into the power inlet.
7. Install power cord into the power inlet on the compressor base.
8. Plug power cord into electrical outlet.
9. Turn the power switch to the On (I) position and check to see that the unit powers up properly.
10. If the unit does not come on, turn the power switch off, unplug the power cord, and call your dealer, provider or Invacare for service.

6 After Use

6.1 Disposal

This product has been supplied from an environmentally aware manufacturer that complies with the Waste Electrical and Electronic Equipment (WEEE) Directive 2012/19/EU.

This product may contain substances that could be harmful to the environment if disposed of in places (landfills) that are not appropriate according to legislation.

The 'crossed out wheelie bin' symbol is placed on this product to encourage you to recycle wherever possible.

Follow local governing ordinances and recycling plans regarding disposal of the device or components normally used in operation. The device does not generate waste or residue in operation. DO NOT dispose of the device in the normal waste stream. Any accessories not part of the device MUST be handled in accordance with the individual product marking for disposal.

Please be environmentally responsible and recycle this product at its end of life. Contact Invacare or your service provider for product recycling information.

7 Troubleshooting

7.1 Indicator Lights

Indicator Light Color	Compressor Status	Effect
None	Compressor is Off.	O ₂ flowing to user if concentrator is on.
O ₂ BELOW NORMAL - YELLOW	Compressor is On and warming up (0-3 minutes after power is On).	Cylinder filling not started.
	O ₂ from concentrator is < 90% (any time after three minute warmup).	O ₂ flowing to user if concentrator is On.
		Cylinder filling stops, will restart when O ₂ > 90%.
		O ₂ flowing to user if concentrator is On.
FILLING - GREEN	Compressor is On and cylinder is filling. O ₂ from concentrator is >90% (any time after three minute warmup).	Cylinder is filling.
		O ₂ flowing to user if concentrator is On.

Indicator Light Color	Compressor Status	Effect
FULL - GREEN	<p>Compressor is On. Cylinder is finished filling (full) -remove cylinder (FULL light is On in >10 mins.)</p> <p>or</p> <p>Cylinder is not attached properly - check connection (FULL light is On in <10 mins.).</p>	<p>Cylinder filling stops.</p> <p>Cannot fill another cylinder until compressor is turned Off and On again.</p> <p>O₂ flowing to user if concentrator is On.</p>
ATTENTION - RED (Audible Alarm)	<p>Compressor is On. Cylinder NOT filling. Causes:</p> <p>Full cylinder attached when unit turned On - replace with empty cylinder</p> <p>or</p> <p>Internal failure - contact dealer.</p>	<p>Compressor does not begin to fill or stops filling.</p> <p>Unit must be turned Off and On before filling can occur.</p> <p>O₂ flowing to user if concentrator is On.</p>

7.2 Troubleshooting

Problem	Solution
<p>No indicator lights on when compressor turned On.</p>	<ol style="list-style-type: none"> 1. Turn compressor Off. 2. Check that power cord is properly plugged into compressor and wall outlet. 3. Turn the compressor On. 4. Clean air filters. <i>5.4 Refer to Cleaning the Compressor Filter on page 33, page 24.</i> 5. If performing Steps 1-4 does not cause any indicator lights to come on, contact your home health care provider or Invacare for service.
<p>RED Light On</p>	<ol style="list-style-type: none"> 1. Check the cylinder gauge to see if it is full: <ul style="list-style-type: none"> • Cylinder full - Remove the cylinder and turn the unit Off. Perform the <i>4.1 Cylinder Prefill Inspection on page 20, page 17</i> with a cylinder that is not full. • Cylinder not full - Proceed to Step 2. 2. Check that the cylinder is connected properly. 3. Turn the compressor Off. 4. Remove the cylinder and reinstall. 5. Turn the compressor On. If cylinder is not full and is connected properly, the compressor may have internal failure. Contact your home health care provider or Invacare.

Problem	Solution
<p>Compressor cycles on and Off</p> <p>or</p> <p>O₂ Below Normal (yellow) and filling (green) lights are alternating</p> <p>or</p> <p>O₂ below normal (yellow) light goes On and Off</p>	<ol style="list-style-type: none"> 1. Check the concentrator liter flow setting is at 3 L/min or less. If necessary, adjust the liter flow setting (refer to the concentrator User manual). Wait at least 20 minutes for the GREEN light to appear. If it does not appear, proceed to step 2. 2. The concentrator may need service, contact your home health care provider or Invacare.
<p>O₂ below normal (YELLOW) light stays On</p>	<ol style="list-style-type: none"> 1. Ensure the concentrator has warmed up for at least 20 minutes. If it has not been 20 minutes, turn the compressor Off until the concentrator warms up. If the YELLOW light still remains on proceed to step 2. 2. Inspect the connection between the compressor and the concentrator for damage or pinching. <ul style="list-style-type: none"> • If damaged, replace. • If pinched, straighten tubing. Turn the compressor Off for at least 10 seconds. Turn the compressor On. If the YELLOW light still remains on after 10 minutes, proceed to step 3. 3. The concentrator may need service, contact your home health care provider or Invacare.

Problem	Solution
<p>Fill times exceed maximum as recommended fill times OR GREEN filling light stays On.</p>	<ol style="list-style-type: none"> 1. Ensure the cylinder regulator is set to Off. 2. Check the recommended fill times shown in the individual cylinder’s manual. 3. Check that the cylinder is connected properly. Turn the compressor Off. Remove the cylinder and reinstall. Turn the compressor On. 4. Check the compressor/concentrator line for proper connection and/or damage (i.e. - leaks or kinks). 5. Check the concentrator liter flow setting is at three L/min or less. If necessary, adjust the liter flow setting (refer to the concentrator User manual). If the GREEN filling light does not go Off, the compressor and/or concentrator may need service. Contact your home health care provider or Invacare.
<p>Excessive noise when compressor is On</p>	<ol style="list-style-type: none"> 1. Call home health care provider or Invacare for service.
<p>Hissing sound from Regulator when flow selector is Off</p>	<ol style="list-style-type: none"> 1. Turn flow selector Off. 2. If hissing sounds continue, call home health care provider or Invacare.
<p>Regulator is On but O₂ is not being delivered</p>	<ol style="list-style-type: none"> 1. Refill cylinder 2. Check that cannula is straight and not pinched. If damaged, replace. 3. Call home health care provider or Invacare for service.

 Refer to the cylinder’s manual for proper fill times.

Filling times are approximate and may vary on environmental conditions.

8 Technical Data

8.1 Technical Description

The HomeFill Oxygen System (IOH200) is an electromechanical prescription system for use in the home. Its intended function and use is to supply pressurized oxygen to fill Invacare proprietary oxygen cylinders for ambulatory use while the patient receives therapeutic oxygen from an accessory oxygen concentrator. The IOH200 HomeFill Compressor is designed for use with any Invacare HomeFill compatible oxygen concentrator with an integral HF2 accessory port that can supply an oxygen concentration greater than 90% O₂ around 2 L/min. while supplying a patient therapy flow rate up to 3.0 L/min.

The HomeFill Oxygen System consists of the IOH200 oxygen compressor, connection tubing, and the Invacare supplied portable oxygen cylinders with interlocking fill fitting.

The IOH200 compressor consists of a multistage compressor, internal reservoir, control electronics with an integral oxygen concentration sensor, interlocking fill fitting, inlet fitting, and drive motor. The compressor operation is controlled by the electronics assembly. The motor/compressor is allowed to fill a cylinder only when the oxygen concentration of the inlet gas stream is greater than 90%. The motor/compressor fill operation is completed when the gas in a cylinder reaches the maximum fill pressure of 2000 PSI (13786 kPa).

The IOH200 oxygen compressor can fill cylinders for portable use by ambulatory patients. The Invacare supplied portable gas cylinders have an interlocking fill fitting that mates only with the Invacare IOH200 compressor assembly.

8.2 Specifications

Regulatory Listings:	Double Insulated Product
	ETL Certified as Complying with UL60601-1, First Edition
	ETL Certified Complying with CAN/CSA C22.2 No. 601-1 M:90 (Canada)
	EMC IEC 60601-1-2
Electrical Requirements: Voltage Input: Rated Current Input:	120 VAC ± 10% (108 VAC/132 VAC), 60 Hz
	2.0 AMP
Operating Temperature:	50 to 95° F (10 to 35° C) @ 20 to 60% non-condensing humidity
Input Pressure Required:	14 - 21 psi
Input Flow Required:	2 L/min
Input O ₂ % Required:	>90% O ₂
Width:	20 ¼ inches
Height:	15 inches
Depth:	16 inches
Weight:	33 lbs
Shipping Weight:	39 lbs

No AP/APG:	Not suitable for use in the presence of a flammable anesthetic mixture.
Electrical:	No extension cords.
Placement:	No closer than 7.5 cm (3 in) from any wall, furniture, draperies, or furniture to assure sufficient air flow. Avoid deep pile carpets and heaters, radiators or hot air registers. Floor location only.
Tubing:	2 m (7 ft) cannula with a maximum 15 m (50 ft) of Crush-Proof Tubing (DO NOT pinch).
Time of Operation:	Up to 24 hours per day.
Recommended Storage and Shipping Temperature:	-29° C to 65° C (-20° F to 150° F) at 15-95% relative humidity.
Environment:	Smoke and soot-free. No confined spaces (Example: No closets).
Minimum Operating Time:	30 Minutes
Altitude:	Sea level to 6000 ft

9 Warranty

9.1 Limited Warranty



THE WARRANTY BELOW HAS BEEN DRAFTED TO COMPLY WITH FEDERAL LAW APPLICABLE TO PRODUCTS MANUFACTURED AFTER JULY 4, 1975.

This warranty is extended only to original purchaser who purchases this product when new and unused from Invacare Corporation or a dealer. This warranty is not extended to any other person or entity and is not transferable or assignable to any subsequent purchaser or User Coverage under this warranty will end upon any such subsequent sale or other transfer of title to any other person. This warranty gives you specific legal rights and you may also have other legal rights which may vary from state to state.

Invacare warrants the HomeFill Compressor to be free from defects in materials and workmanship for a period of one year from date of purchase from Invacare or a dealer, with a copy of the seller's invoice required for coverage under this warranty.

Invacare warrants the HomeFill internal wear components (piston seals and rings, bearings, drive belts, check valves, pressure relief components and electric motor) for a period of three years from the date of purchase from Invacare or a dealer, with a copy of the seller's invoice required for coverage under this warranty, or 5,000 hours, whichever comes first.

Invacare warrants the HomeFill control panel components (electrical switches, reset switch and indicator lights) for a period of three years from the date of purchase from

Invacare or a dealer, with a copy of the seller's invoice required for coverage under this warranty, or 5,000 hours, whichever comes first.

For Model Nos. IOH2MD, IOH2M6 and IOH2M9, Invacare warrants the HomeFill regulator (NOT including the cylinder) to be free from defects in materials and workmanship for a period of two years from date of purchase from Invacare or a dealer, with a copy of the seller's invoice required for coverage under this warranty.

For Model Nos. HF2PCL4, HF2PCL6 and HF2PC9, Invacare warrants the HomeFill regulator (NOT including the cylinder) to be free from defects in materials and workmanship for a period of two years from date of purchase from Invacare or a dealer, with a copy of the seller's invoice required for coverage under this warranty.

DO NOT OPEN OR ATTEMPT TO SERVICE UNLESS SERVICE IS PROVIDED BY AN INVACARE-CERTIFIED TECHNICIAN; otherwise, this will void any and all warranties. If within such warranty periods any such product shall be proven to Invacare's satisfaction to be defective, such product shall be repaired or replaced, at Invacare's option. This warranty only applies to the labor for repairs performed by the Invacare Service Department or Invacare dealers. It does not apply to the labor performed by the purchaser or user. This warranty does not include normal wear and tear, failure to adhere to the product instructions, or shipping charges incurred in replacement part installation or repair of any such product. Invacare's sole obligation and your exclusive remedy under this warranty shall be limited to such repair or replacement. Routine maintenance items, such as filters, are excluded from this warranty.

For warranty service, please contact Invacare's service department at the toll free number on the back page during normal working hours.

Upon receiving notice of an alleged defect in a product, Invacare will issue a serialized return authorization. It shall be the responsibility of the purchaser, at the purchaser's cost, to return the unit, pack the unit in a manner to avoid shipping damage and to ship the unit to either Invacare's plant or service center as specified by Invacare in advance. Defective units must be returned for warranty inspection using the serial number as identification within thirty days of return authorization date. Do not return products to our factory without prior consent. C.O.D. shipments will be refused; please prepay shipping charges.

LIMITATIONS AND EXCLUSIONS: THE FOREGOING WARRANTY SHALL NOT APPLY TO PRODUCTS SUBJECTED TO NEGLIGENCE, ACCIDENT, IMPROPER OPERATION, MAINTENANCE OR STORAGE, SOOT OR SMOKE-FILLED ENVIRONMENTS, OR OTHER THAN NORMAL APPLICATION, USE OR SERVICE, OR TO PRODUCTS MODIFIED WITHOUT INVACARE CORPORATION'S EXPRESS WRITTEN CONSENT (INCLUDING, BUT NOT LIMITED TO, MODIFICATION THROUGH THE USE OF UNAUTHORIZED PARTS OR ATTACHMENTS) OR TO PRODUCTS DAMAGED BY REASON OF REPAIRS MADE TO ANY COMPONENT WITHOUT THE SPECIFIC CONSENT OF INVACARE CORPORATION OR TO PRODUCTS DAMAGED BY CIRCUMSTANCES BEYOND INVACARE CORPORATION'S CONTROL.

THE FOREGOING EXPRESS WARRANTY IS EXCLUSIVE AND IN LIEU OF ANY OTHER WARRANTIES WHATSOEVER, WHETHER EXPRESS OR IMPLIED, INCLUDING THE IMPLIED WARRANTIES OF MERCHANTABILITY AND FITNESS FOR A PARTICULAR

PURPOSE, AND THE SOLE REMEDY FOR VIOLATIONS OF ANY WARRANTY WHATSOEVER, SHALL BE LIMITED TO REPAIR OR REPLACEMENT OF THE DEFECTIVE PRODUCT PURSUANT TO THE TERMS CONTAINED HEREIN. THE APPLICATION OF ANY IMPLIED WARRANTY WHATSOEVER SHALL NOT EXTEND BEYOND THE DURATION OF THE EXPRESS WARRANTY PROVIDED HEREIN. INVACARE SHALL NOT BE LIABLE FOR ANY CONSEQUENTIAL OR INCIDENTAL DAMAGES WHATSOEVER.

SOME STATES DO NOT ALLOW THE EXCLUSION OR LIMITATION OF INCIDENTAL OR CONSEQUENTIAL DAMAGE, OR LIMITATION OF HOW LONG AN IMPLIED WARRANTY LASTS, SO THE ABOVE EXCLUSION AND LIMITATION MAY NOT APPLY TO YOU.

THIS WARRANTY SHALL BE EXTENDED TO COMPLY WITH STATE/PROVINCIAL LAWS AND REQUIREMENTS.

Invacare Corporation

USA

One Invacare Way

Elyria, Ohio USA

44036-2125

800-333-6900

Technical Services: 800-832-4707

www.invacare.com



1100873-M 2018-05-22



Making Life's Experiences Possible®



Manufacturer

Invacare Corporation

2101 E. Lake Mary Blvd.

Sanford, FL USA 32773

407-321-5630



Yes, you can.®