

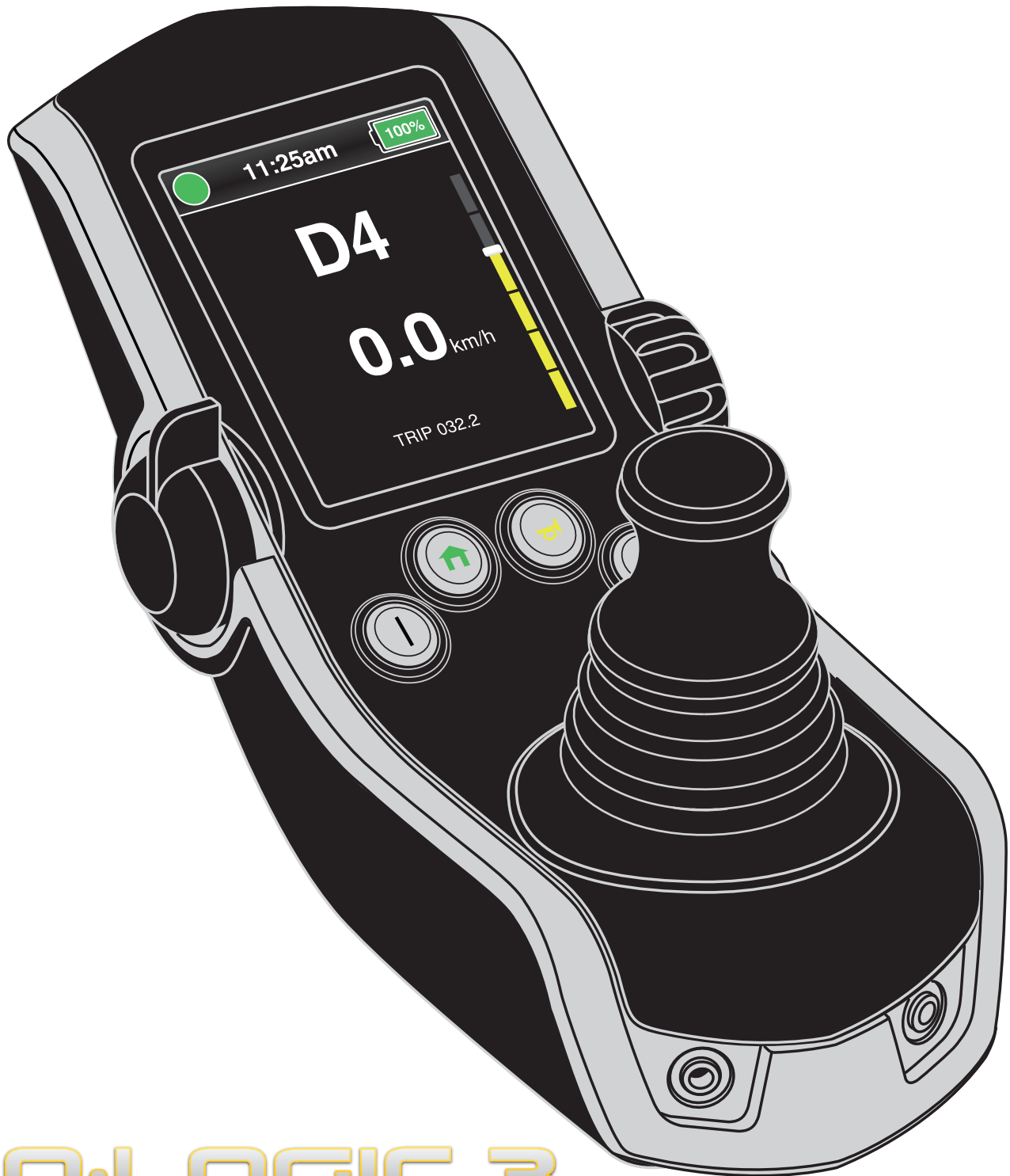

# Basic Operation Instructions









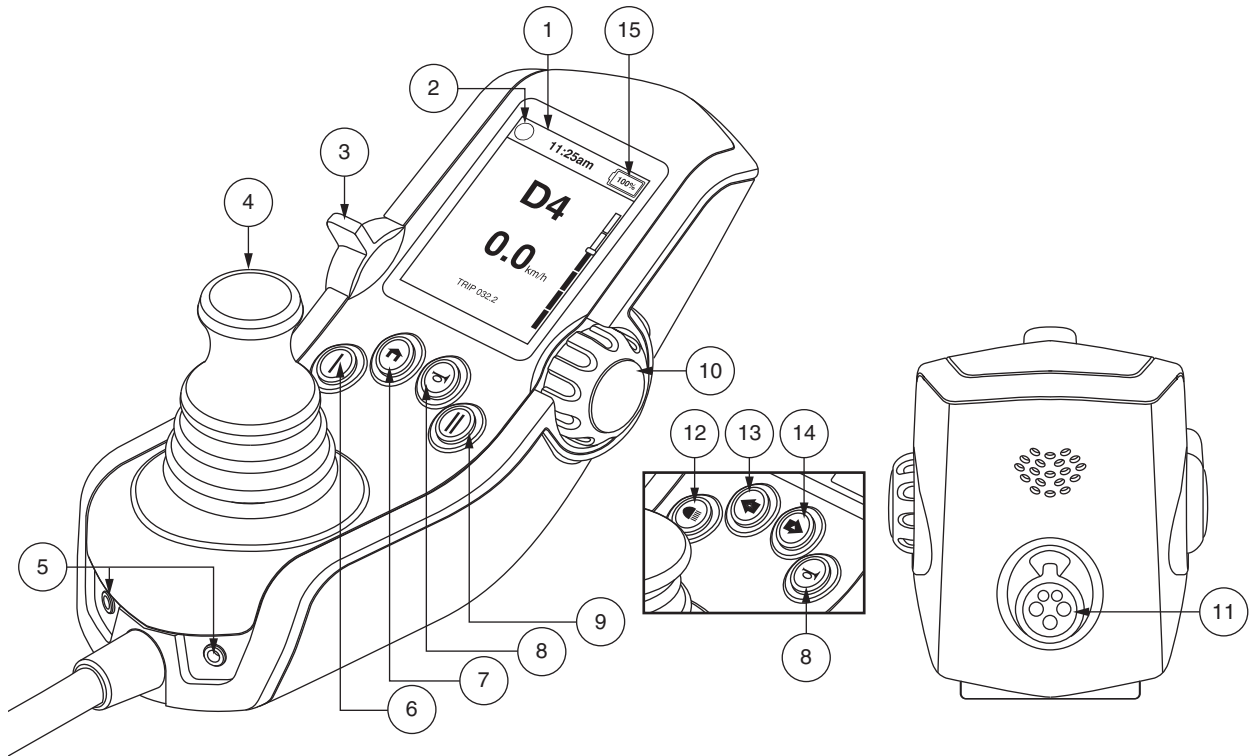

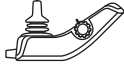







**Q·LOGIC 3**

Advanced Drive Control System







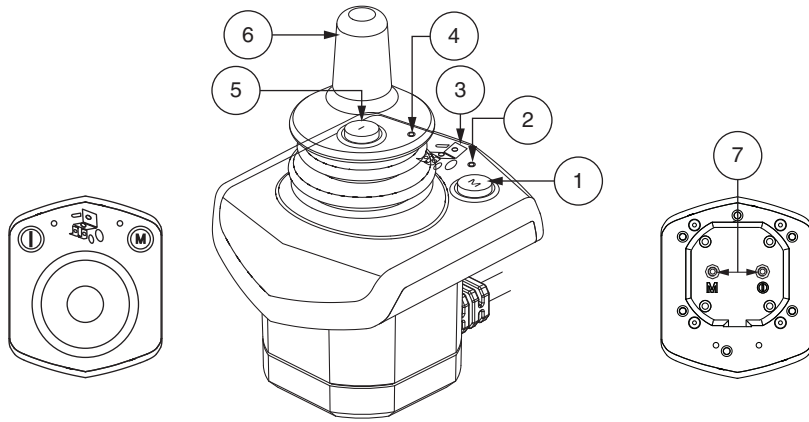

# Identification Key











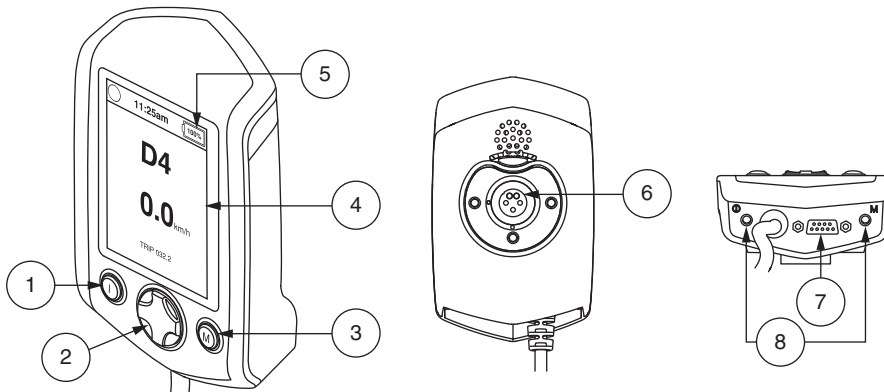

 <b>Controller</b>	 <b>LCD Screen</b>	 <b>Drive/Function Inhibit</b>	 <b>On/Off Mode Select Lever</b>
 <b>Joystick</b>	 <b>On/Off and Mode Jacks</b>	 <b>Key 1 Select Button</b>	 <b>Home Button</b>
 <b>*Horn Button</b>	 <b>Key 2 Select Button</b>	 <b>Speed Adjustment</b>	 <b>Charger Port</b>
 <b>*Light Button</b>	 <b>*Left Turn Indicator Button</b>	 <b>*Right Turn Indicator Button</b>	 <b>Battery Condition Meter</b>

\*Optional components available on some models



 <b>Attendant Control</b>	 <b>Mode Button</b>	 <b>Mode LED</b>	 <b>Actuator Indicators</b>
 <b>Battery Condition Meter</b>	 <b>On/Off Button</b>	 <b>Joystick</b>	 <b>On/Off and Mode Jacks</b>



 <b>Enhanced Display</b>	 <b>On/Off Button</b>	 <b>4-Direction Navigation Key</b>	 <b>Mode Button</b>
 <b>LCD Screen</b>	 <b>Battery Condition Meter</b>	 <b>Charger/Programmer Port</b>	 <b>9-pin D-sub Connector</b>
 <b>On/Off and Mode Jacks</b>			



**WARNING!** A Quantum Rehab Provider or a qualified technician must perform the initial setup of this product and must perform all of the instructions in this manual.

The symbols below are used throughout this owner's manual and on the power chair to identify warnings and important information. It is very important for you to read them and understand them completely.



**WARNING!** Indicates a potentially hazardous condition/situation. Failure to follow designated procedures can cause either personal injury, component damage, or malfunction. On the product, this icon is represented as a black symbol on a yellow triangle with a black border.



**MANDATORY!** These actions should be performed as specified. Failure to perform mandatory actions can cause personal injury and/or equipment damage. On the product, this icon is represented as a white symbol on a blue dot with a white border.



**PROHIBITED!** These actions are prohibited. These actions should not be performed at any time or in any circumstances. Performing a prohibited action can cause personal injury and/or equipment damage. On the product, this icon is represented as a black symbol with a red circle and a red slash.

***NOTE:*** These instructions are compiled from the latest specifications and product information available at the time of publication. We reserve the right to make changes as they become necessary. Any changes to our products may cause slight variations between the illustrations and explanations in this manual and the product you have purchased. The latest/current version of this manual is available on our website.

***NOTE:*** This product is compliant with WEEE, RoHS, and REACH directives and requirements.

***NOTE:*** This product meets IPX4 classification (IEC 60529).

***NOTE:*** The Q-Logic 3 Controller and its components are not made with natural rubber latex. Consult with the manufacturer regarding any after-market accessories.

---

<b>Label Information .....</b>	<b>6</b>
<b>The Q-Logic 3 Controller .....</b>	<b>7</b>
<b>Precautionary Guidelines .....</b>	<b>7</b>
<b>Operating the Q-Logic 3 Controller .....</b>	<b>7</b>
On/Off and Mode Select Lever .....	7
Joystick.....	7
Lock/Unlock Procedure .....	8
Speed Adjustment Knob.....	8
Keypad.....	8
Horn Button .....	8
Home Button.....	8
Key 1 and Key 2 Button .....	9
Light Button .....	9
Left/Right Turn Indicator Button .....	9
LCD Screen.....	9
Drive Screen.....	10
Drive Profile Selection .....	11
Actuator Adjustment (Seat Screen).....	11
iLevel® Feature (Optional).....	13
Settings Screen .....	15
Bluetooth® Functions .....	20
Standby Select Menu .....	25
<b>Attendant Control/Stand-Alone Joystick.....</b>	<b>25</b>
<b>Enhanced Display.....</b>	<b>26</b>
<b>Sleep Mode.....</b>	<b>27</b>
<b>Thermal Rollback.....</b>	<b>27</b>
<b>Battery Condition Meter.....</b>	<b>27</b>
<b>Q-Logic 3 Error Codes .....</b>	<b>27</b>
<b>Care and Maintenance .....</b>	<b>29</b>
<b>Temperature.....</b>	<b>29</b>
<b>Warranty .....</b>	<b>29</b>

## Product Safety Symbols

The symbols below are used on the controller to identify warnings, mandatory actions, and prohibited actions. It is very important for you to read and understand them completely.



**Read and follow the information in the owner's manual.**



**Avoid exposure to rain, snow, ice, salt, or standing water whenever possible. Maintain and store in a clean and dry condition.**



**EMI/RFI—This product has been tested and passed at an immunity level of 20 V/m.**



**Disposal and recycling – Contact your Quantum Rehab Provider for information on proper disposal and recycling of your Quantum product and its packaging.**

## The Q-Logic 3 Controller

The Q-Logic 3 Controller is a fully programmable, modular electronic controller system that allows you to operate your power chair. The Q-Logic 3 has several input devices available that operate through a power module. The hand control will primarily be discussed in this manual along with references to the Enhanced Display, Stand-alone Joystick, and Attendant Control. Additional input devices are also available for the Q-Logic 3. Contact your Quantum Rehab Provider for more information.

The controller has been pre-programmed to meet a typical user's needs. The program is adjusted using either a personal computer with software provided by the controller manufacturer or with a hand-held programmer, also provided by the controller manufacturer, by your Quantum Rehab Provider or a trained service technician.



**WARNING!** The controller program can affect speed, acceleration, deceleration, dynamic stability, and braking. If it is programmed incorrectly or outside of the safe limits as determined by your healthcare professional, it can create a dangerous situation. Only your Quantum Rehab Provider or a trained service technician should program your controller.

## Precautionary Guidelines

Before operating the Q-Logic 3 Controller please read the following. These guidelines are provided for your benefit and will aid you in the safe operation of the seating system.

- Turn off the power to the controller before you are seated in your power chair.
- Always have assistance when you are being seated in your power chair.
- Follow all of the procedures and heed the warnings as explained in your power chair owner's manual and Consumer Safety Guide.

## Operating the Q-Logic 3 Controller

The Q-Logic 3 hand control is used to operate your power chair and all of its components.

### On/Off and Mode Select Lever

The On/Off and Mode Select lever turns the system on and off, is used to recycle the power, and is also used to select drive profiles, seating and auxiliary menus.



**WARNING!** When faced with an emergency situation, release the joystick, then press the on/off to stop the power chair. Use caution. Be advised that pressing the on/off button may cause the power chair to stop abruptly.

**WARNING!** Always turn the power off when you are stationary to prevent unexpected movement.

### Joystick

The joystick controls the driving speed and direction of the power chair and is used to navigate the menus on the LCD screen. When the joystick is at rest, it is in the neutral (center) position and the chair is stationary. In order to drive the chair, the joystick must be taken out of neutral. Moving the joystick in any direction will switch the chair from neutral to drive, and the chair will move in the direction indicated by the joystick position. The farther away from the neutral position the joystick is, the faster the chair will move in that direction. To stop chair movement, simply release the joystick or move it back to the neutral position. The chair's electromagnetic brakes will engage after the chair has come to a controlled stop.

## Lock/Unlock Procedure

The Q-Logic 3 Controller comes with a programmable lock/unlock option.

**NOTE: The lock-out feature is not programmed at the factory. To have this feature added, contact your Quantum Rehab Provider.**

### To lock the controller

1. Push the On/Off and Mode Select Lever up once to power on the chair and the controller.
2. Push and hold the On/Off and Mode Select Lever in the on position until the controller turns off. The controller is now locked.

### To unlock the controller:

1. Push the On/Off and Mode Select Lever up once to power on the chair and the controller. The words "System Lock" will appear on the display screen.
2. Move the joystick to the full forward position until you hear a beep.
3. Move the joystick to the full reverse position until you hear a beep.
4. Release the joystick. The controller is now unlocked.

## Speed Adjustment Knob

The speed adjustment knob is used to control the speed of the power chair.

### To change the speed:

1. Push the On/Off and Mode Select Lever up once to power on the chair and the controller.
2. To increase your speed, turn the speed adjustment knob up.
3. To decrease your speed, turn the speed adjustment knob down.

The speed indicator bar will increase and decrease as the speed knob is moved, providing a visual display of how fast the chair will move.

## Keypad

The keypad is located directly in front of the joystick. It contains the components that you will use to control your power chair.

## Horn Button

The horn button activates a warning horn.

## Home Button

The home button is used to quickly access Drive Mode, Seat Mode (if equipped), Settings Mode, and Environmental Functions.

**NOTE: If no Environmental Functions are selected in the Settings, the Environmental Functions icon will not be displayed.**

### To access the Home Screen if your chair is equipped with a light joystick:

1. Push both the Left/Right Indicators for several seconds.

**NOTE: The timing is a programmable parameter that can be reset by your Quantum Rehab Provider.**



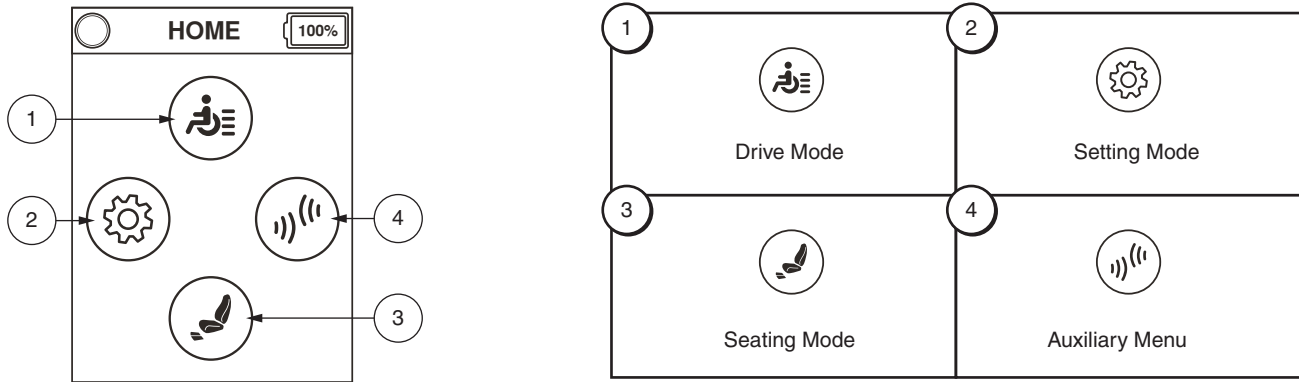

### Key 1 and Key 2 Select Buttons

The key 1 select button is used to quickly and easily select drive profile 1. The key 2 select button selects the seat. Key 1 and key 2 select buttons can be customized. Contact your Quantum Rehab Provider for more information. See Identification Key on page 4 for reference.

**NOTE: If your Q-Logic 3 Controller is equipped with a lighting system, the Home button and key 1/key 2 select buttons will be replaced with a light button and left/right turn indicator buttons.**

### Light Button

The light button controls the front headlights and rear running lights.

### To operate the lights:

1. Push the On/Off and Mode Select Lever up once to power on the chair and the controller.
2. Press the light button once to activate the front headlights and rear running lights.
3. Press the light button again to turn off the lighting system.

### Left/Right Turn Indicator Buttons

The left/right turn indicator buttons toggle either the left or right turn indicators.

### To operate the turn indicators:

1. Push the On/Off and Mode Select Lever up once to power on the chair and the controller.
2. Press the desired turn indicator button once to turn on that indicator.
3. Press the same turn indicator button again to turn off that indicator.

**NOTE: If the left turn indicator is activated, pressing the right indicator button will turn off the left indicator and activate the right indicator.**

**NOTE: The turn indicator buttons also control the hazard lights. Press both turn indicator buttons at the same time to activate the hazard lights and press both buttons again to turn off the hazard lights. If the hazard lights are left on and the controller is turned off, the hazard lights will continue to flash. The Q-Logic 3 must be turned back on and both turn indicator buttons must be pressed to deactivate the hazard lights.**

### LCD Screen

The Q-Logic 3 provides the user with easily intuited feedback information via the LCD screen. The circle at the top left of the screen represent a stoplight. A green light indicates full drive operation, an amber light indicates limited drive operation, and a red light indicates that drive operation is prohibited.

### Drive Screen

The LCD provides the current time in either 12- or 24-hour clock format, the current profile, drive operation, the speed adjustment setting, and the trip odometer, or the overall odometer reading.

Drive/Function Inhibit status is depicted as a green light at the top left of the screen. Actuator adjustment will affect the inhibit status. As your seat and/or back angle increases, a red light will indicate full drive lockout. If your power chair is equipped with a seat lift, a yellow light will indicate speed reduction as the seat is elevated. To return your power chair to green status, reverse operation.

#### To access the Drive Screen

1. Push the Home Sree button.
2. Push the joystick up for "Drive Screen."

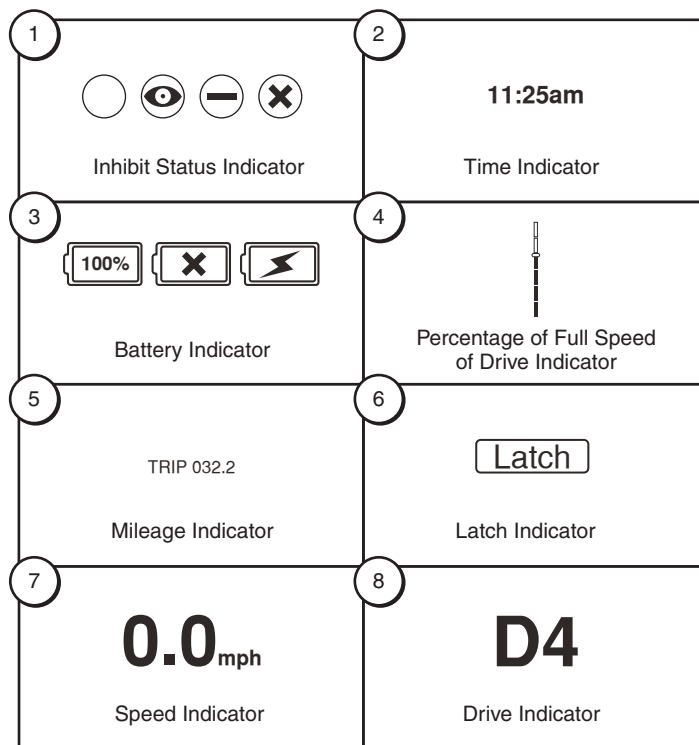
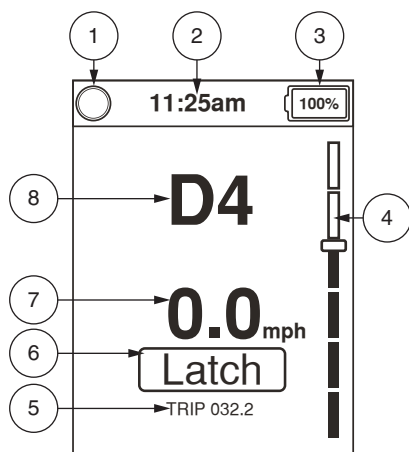

## Drive Profile Selection

Your Q-Logic 3 Controller may be programmed for up to four drive profiles that allow the system to be custom-tailored to your environment. The drive profile may be changed two different ways. Profiles **1 – 4** may be selected by pressing the On/Off and Mode Select Lever in the forward direction. Profile 1 may be selected by simply pressing the key 1 select button. The selected profile is displayed on the Drive Screen.

**NOTE: Drive profiles are set by your Quantum Rehab Provider. Contact your Quantum Rehab Provider to change or add a drive profile.**

### To select a profile setting using the On/Off and Mode Select Lever:

1. Push the On/Off and Mode Select Lever up once to power on the chair and the controller.
2. Push the On/Off and Mode Select Lever up again to select a drive profile. Cycle through the four available drive profiles.
3. Continuing to push the lever up will cycle through the Auxiliary screen and Seat screen (if power positioning is present), then back to Drive profile 1.

**NOTE: You can only scroll forward through the drive profiles. Pushing the On/Off and Mode Select Lever down will power off the controller.**



**WARNING! Drive/Function Inhibit status is read-only in your actuator adjustment (seat screen). This function is disabled in drive mode in order to prevent unintended loss of function in your power chair. Take caution when negotiating, obstacles, ramps, and inclines. Whenever possible, use an attendant in these conditions.**

**WARNING! Operating your power chair on inclines and/or with tilt/recline function will affect your power chair's stability.**

## Actuator Adjustment (Seat Screen)

The Q-Logic 3 Controller can control five power seat actuators using the mode select lever and the joystick.

### To select and adjust an actuator:

1. Push the On/Off and Mode Select Lever up once to power on the chair and the controller.
2. Push the On/Off and Mode Select Lever up several times until the seat screen is displayed on the LCD or push the key 2 select button once to go directly to actuator mode.
3. Push the joystick to the left or right to cycle through the available actuators until the desired actuators are illuminated on the actuator indicator. **See figure 1.**
4. When the desired actuator is selected, give a forward command to the joystick to adjust position in one direction or give a reverse command to the joystick to adjust position in the opposite direction. If you continue to push the lever up, it will cycle through the Drive screens and Auxiliary screen, and then return to Seat Screen.
5. Push up and release the On/Off and Mode Select Lever until you return to the desired drive profile.

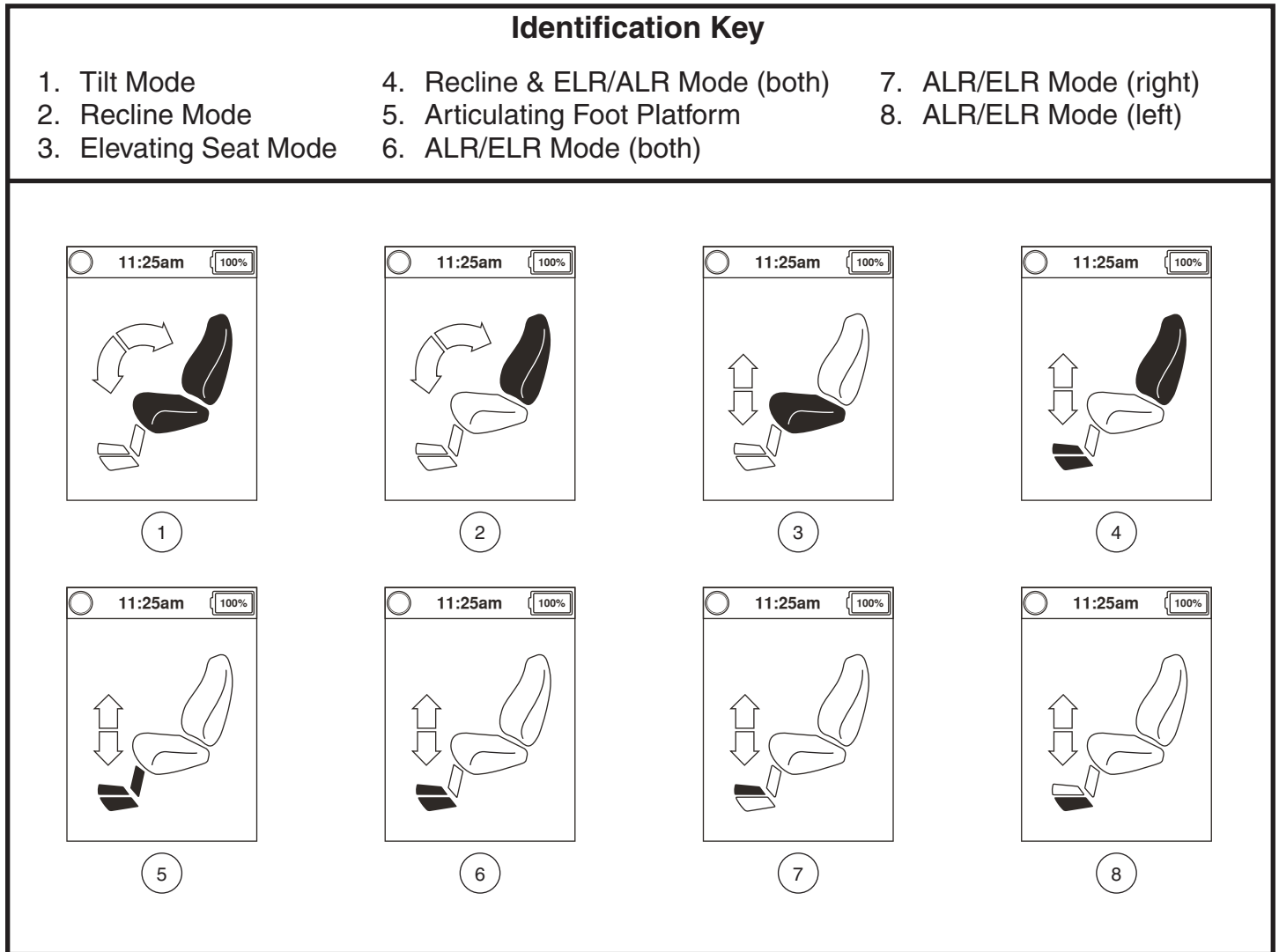

Figure 1. Actuator Selection

**NOTE: The Drive/Function Inhibit status is affected only in the actuator adjustment (seat screen)..**

## iLevel® Feature (Optional)

Your power chair may be equipped with the iLevel® feature that will be used in conjunction with your TRU-Balance® 3 Power Positioning System. The iLevel® feature is mounted on a Quantum power base for enhanced stability when the seating system is elevated.

There are certain situations, including some medical conditions, where the power chair user will need to practice operating the power chair equipped with iLevel® in the presence of a trained attendant. A trained attendant can be defined as a family member or care professional specially trained in assisting a power chair user in various daily living activities.

As you begin using iLevel® during daily activities, you will probably encounter situations in which you will need some practice. Simply take your time and you will soon be in full and confident control.

## Elevation (Seat Screen)

The iLevel® feature can be activated by selecting the elevating seat actuator.

### To select and adjust the seat elevation using the Q-Logic 3 Controller:

1. Push the On/Off and Mode Select Lever up once to power on the chair and the controller.
2. Push the On/Off and Mode Select Lever up several times until the seat screen is displayed on the LCD or push the key 2 select button once to go directly to seat screen. **See figure 1.**
3. Push the joystick to the left or right to cycle through to the elevating seat mode, this is illuminated on the actuator indicator. **See figure 1.**

**NOTE: If your Q-logic 3 settings are different than those described, contact your Quantum Rehab Provider. Your Quantum Rehab Provider may have changed the programming of your Q-Logic 3 Controller.**

4. When the elevating seat mode is selected, give a forward command to the joystick to adjust position in one direction or give a reverse command to the joystick to adjust position in the opposite direction.
5. If you want to return to another profile, push up and release the On/Off and Mode Select Lever until you return to the desired drive profile.

### To activate the iLevel® using a single switch:

1. Press once and hold the single switch once to raise the seat and activate iLevel®.
2. Press and hold the single switch to lower the seat.

**NOTE: The iLevel® feature is automatically engaged when the power elevating seat is activated and the iLevel® indicator is displayed on your controller. See figure 2.**

The power chair should be used on an indoor, level surface, such as malls, offices, and/or medical facilities to activate iLevel®. Once the seating system actuator is started, the iLevel® boots inhibit movement on the front caster arms. The seating system can be reclined or tilted up to 20° while the iLevel® feature is activated.

**WARNING!** The iLevel® feature should be used only on a flat, level, indoor surface, such as in malls, offices, and/or medical facilities. Never raise the seat from its lowest position on an inclined surface. Failure to heed this warning can result in the power chair tipping over.

**WARNING!** The iLevel® feature is intended for limited outdoor use on only flat level, hardscape surfaces. If you are unsure of your environment, do not use iLevel® outdoors.



**WARNING!** Never raise the seat into iLevel® when operating your power chair on bumpy or uneven surfaces. Failure to heed this warning can result in the power chair tipping over.



**WARNING!** Always fasten the positioning belt when operating the power chair.

**WARNING!** Do not operate the iLevel® or change the seat height in any way while your power chair is positioned under a fixed object, such as a table or a desk. Keep area clear prior to and during movement.

**PROHIBITED!** Never use the iLevel® outdoors on uneven terrain (gravel, hills or other uneven, non-compact terrain) or in fields.

**PROHIBITED!** Never use iLevel® while ascending or descending a curb or uneven surface of any height.

**NOTE:** The iLevel® feature is equipped with a system that allows the power chair to drive a predetermined, safe speed when the seat is elevated. Always check to be sure this system is operating properly before using your power chair.

**NOTE:** If a warning appears on the Q-Logic 3 controller LCD stating "iLevel® is not engaged," the power chair's speed will be reduced to 25% when elevated. If this warning appears while on level ground, please discontinue use of iLevel® feature and consult your Quantum Rehab Provider for assistance.

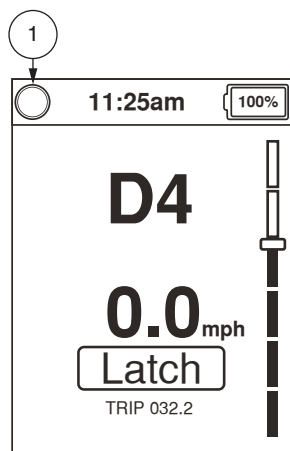
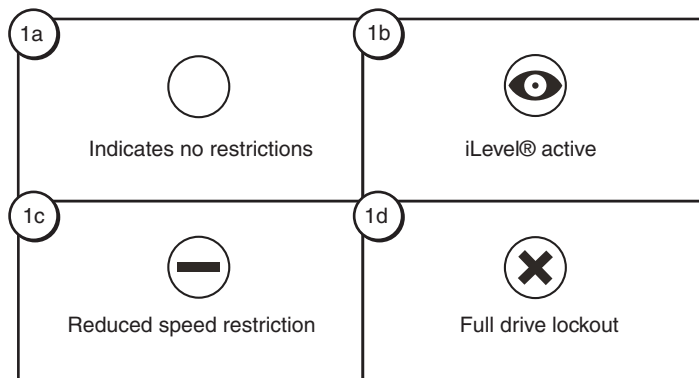

Figure 2. Q-Logic 3 Controller Indicators



#### Definitions of indicators

- 1a No restrictions
- 1b. iLevel® active
- 1c. Reduced speed restriction
- 1d. Full drive lockout

## Settings Screens

The following pages explain the various screens you will use with the Q-Logic 3 Controller. Contact your Quantum Rehab Provider with any questions you may have.

**NOTE: Some screens in this Basic Operating Instructions may differ from your system depending on configuration and options selected.**

### To change a sound setting:

1. Push the Home Screen button.
2. Push the joystick left to enter settings screen.
3. Push the joystick up or down through the available setting subjects.
4. When the desired subject is highlighted on the settings screen, push the joystick to the right to enter that subject.

**NOTE: At any time a left command will return to the previous menu.**

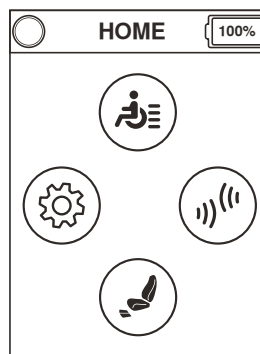

Home Screen

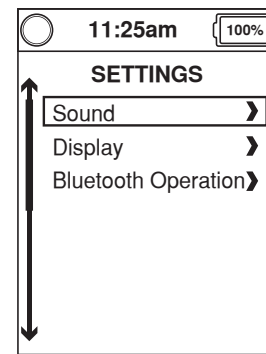

Settings

After "Sound" is highlighted, a right command will show.

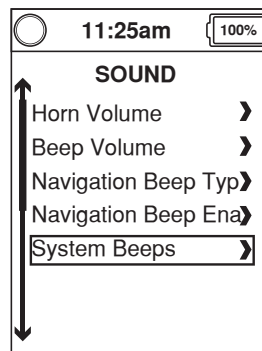

Sound

After "System beeps" is highlighted, a right command will show.

When a setting has a box, a right command "checks" (enables that setting). Another right command will "uncheck" (disable that setting).

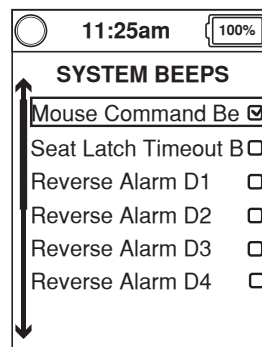

System Beeps

**NOTE: Any time a setting is changed, the system will back up the configuration to the power base. When the system is turned off, "parameter backup in progress" will be displayed on the screen before the system turns off.**

### To change the Display settings:

1. Push the Home Screen button.
2. Push the joystick left to enter settings screen.
3. Push the joystick up or down through the available setting subjects.
4. When the desired subject is highlighted on the settings screen, push the joystick to the right to enter that subject.

**NOTE: At any time a left command will return to the previous menu.**

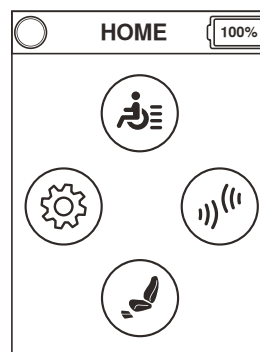

Home Screen

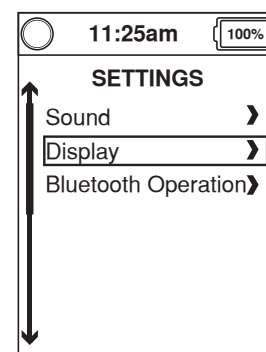

Settings

After "Display" is highlighted, a right command will show.

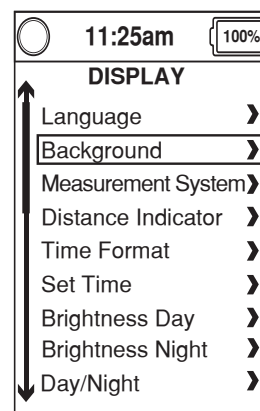

Display

After "Backgrounds" is highlighted, a right command will show.

When a setting has a box, a right command "checks" (enables that setting). Another right command "unchecks" (disables that setting).

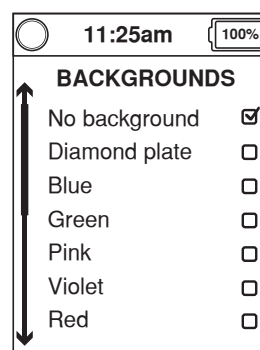

Backgrounds



**To enable/disable and Environmental Function:**

1. Push the Home Screen button.
2. Push the joystick left to enter settings screen.
3. Push the joystick up or down through the available setting subjects.
4. When the desired subject is highlighted on the settings screen, push the joystick to the right to enter that subject.

**NOTE: At any time a left command will return to the previous menu.**

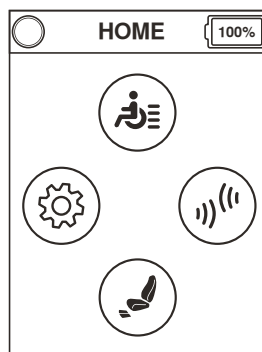

Home Screen

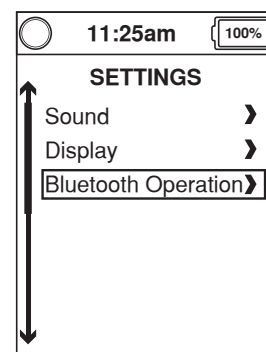

Settings

After "Bluetooth operation" is highlighted, a right command will show.

This Bluetooth screen will enable what Environmental Functions are available on the Environmental Functions Screen.

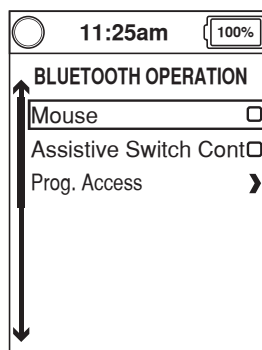

Bluetooth

**NOTE: There are two Bluetooth screens: One is located under Settings and the other under Environmental Controls.**

### To change the Clock settings:

1. Push the Home Screen button.
2. Push the joystick left to enter settings screen
3. Push the joystick up or down through the available settings subjects.
4. When the desired subject is highlighted on the settings screen, push the joystick to the right to enter that subject.

**NOTE: At any time a left command will return to the previous menu.**

After "Display" is highlighted, a right command will show.

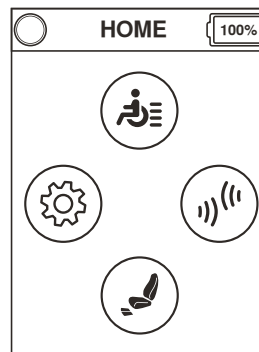

Home Screen

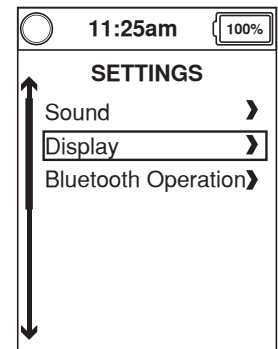

Settings

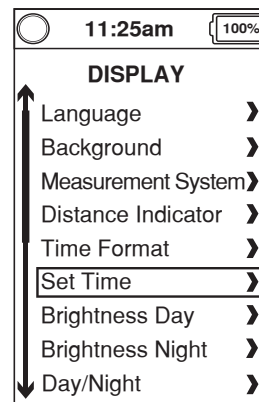

Display

After "Set time" is highlighted, a right command will show.

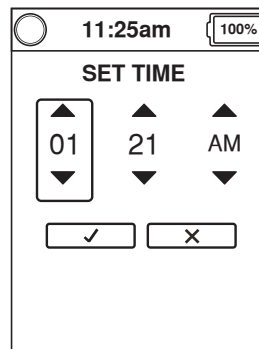

Time

### To set time from the set time screen:

1. Push the joystick left or right to highlight the selection to change. Push the joystick up or down to adjust the value.
2. To set or cancel the adjusted value, move the joystick left or right to highlight "set" or "cancel" then move the joystick up to perform the highlighted function.

The Q-Logic 3 display includes a sensor that will adjust screen brightness for daytime or nighttime. "Brightness Day" sets the brightness of the screen for daytime viewing (bright light). When using the Q-Logic 3 in bright light, use the "Brightness Day" setting to adjust the illumination of the screen. "Brightness Night" sets the screen brightness for nighttime viewing (low light). Use the "Brightness Night" setting to adjust the illumination of the screen in low light.

### To change the auto brightness settings:

1. Push the Home Screen button.
2. Push the joystick left to enter the settings screen.
3. Push the joystick up or down through the available setting subjects.
4. When the desired subject is highlighted on the settings screen, push the joystick to the right to enter that subject.

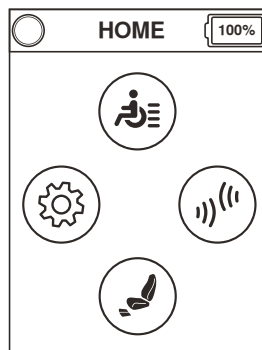

Home Screen

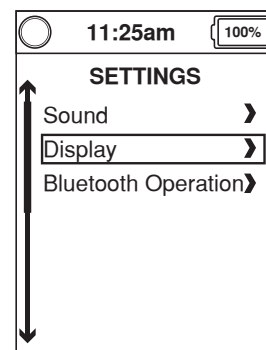

Settings

After "Display" is highlighted, a right command will show.

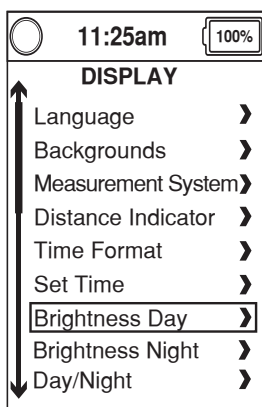

Display

After "Brightness Day" is highlighted, a right command will show.

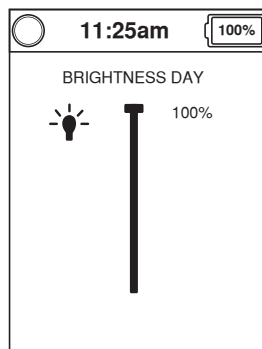

Brightness

### After "Brightness Day" from the Display screen:

1. Push the joystick right to switch between day and night.
2. Push the joystick up or down to adjust brightness, value will change 5% for every push of joystick.
3. Push the joystick left to exit (and accept setting).

To activate the Bluetooth function: 

*The Q-Logic 3 hand control is equipped with built-in Bluetooth that allows you to connect to a computer, smartphone or tablet.*

Push the On/Off and Mode Select Lever up once to power on the chair and controller.

1. Push the home button to access the home screen.
2. Push the joystick to the right to access the Environmental Functions menu.
3. Use the joystick to highlight the Bluetooth function you wish to enable, then push the joystick to the right to select that function.
4. Once in the Bluetooth function the input of the chair can be used to navigate through the connected device.
5. Press the home button to return to the home screen.

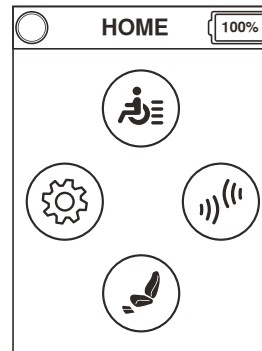

Home Screen

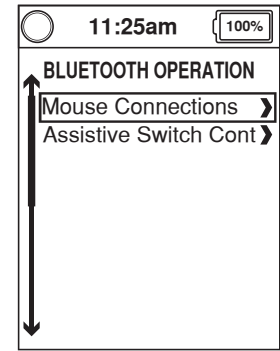

Bluetooth

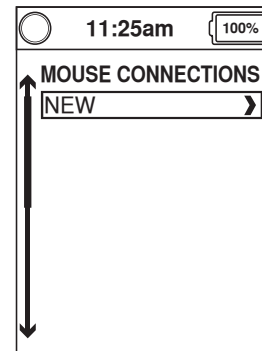

Bluetooth

Mouse Connections is used to pair the Q-Logic 3 to a Bluetooth mouse, allowing the input from the Q-Logic 3 to act as a mouse input in place of the mouse. The mouse feature can be connected to computers that use a Windows or Mac operating system. Bluetooth dongles can also be connected, but refer to the dongles instructions for compatible operating systems.

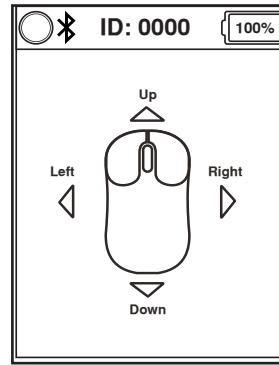

Prog Access and Prog Access iOS can be enabled by highlighting the desired function then pushing the joystick to the right. Pushing the joystick to the right again will disable the function.

***NOTE: Program access may either be in the Settings screen or the Aux screen depending upon configuration.***

***NOTE: When pairing the Q-Logic 3 system to your device, the Q-Logic 3 Bluetooth ID# is at the top of the screen for easy pairing. Please refer to your device for pairing instructions.***

Prog Access Econ-w allows the Q-Logic 3 to be programmed by a dealer of medical equipment through a paired Windows device. Prog Access Econ-w must be enabled to allow the dealer of medical equipment access to the Q-Logic 3 parameters for adjustment. If Prog Access Econ-w is not enabled (even if the dealer of medical equipment has been paired with the Q-Logic 3 previously) the Q-Logic 3 cannot be programmed by the dealer of medical equipment.

Prog Access Econ-i allows the Q-Logic 3 to be programmed by a dealer of medical equipment through a paired iOS device. Prog Access Econ-i must be enabled to allow the dealer of medical equipment access to the Q-Logic 3 parameters for adjustment, if Prog. Access Econ-i is not enabled (even if the dealer of medical equipment has been paired with the Q-Logic 3 previously) the Q-Logic 3 cannot be programmed by the dealer of medical equipment.

***NOTE: Once the dealer of medical equipment has completed programming or if the connection is lost, the dealer of medical equipment must re-pair the device with the Q-Logic 3 to perform any additional programming.***

**To activate the Mouse Connections function through the Environmental Functions Screen:**

1. Push the Home Screen button.
2. Push the joystick right for Environmental Functions screen.
3. Push the joystick up or down through the available Environmental Functions.
4. When the "Mouse Connections" subject is highlighted on the Auxiliary screen, push the joystick to the right.

**NOTE: At any time a left command will return to the previous menu.**

After "Mouse Connections" is highlighted, a right command will show.

**NOTE: Gray icons indicate unpaired Q-Logic 3, blue icons indicate paired Q-Logic 3.**

**NOTE: To leave the mouse screen, press the on/off lever up, key 1, home key, or key 2.**

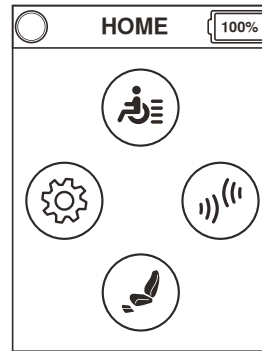

Home Screen

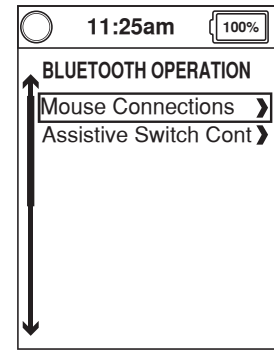

Bluetooth

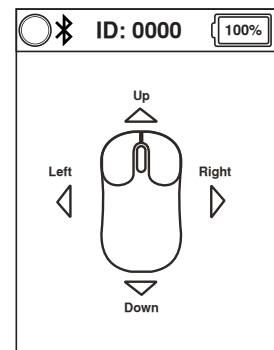
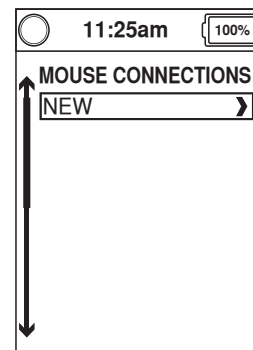

### To make a selection from the Environmental Functions Screen

1. Push the Home Screen button.
2. Push the joystick right for "Environmental Functions Screen".
3. Push the joystick up or down through the available Environmental Functions.

**NOTE: When in the Environmental Functions Screen a left command will show the Auxiliary Screen.**

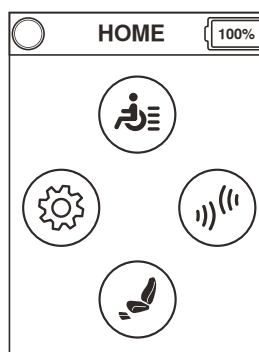

Home Screen

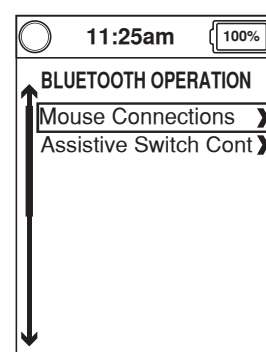

Bluetooth

### To activate the Assistive Switch Control Connections function through the Environmental Functions Screen:

1. Push the Home Screen button.
2. Push the joystick right for "Environmental Functions Screen".
3. Push the joystick up or down through the available Environmental Functions Screen.
4. Assistive Switch Control Connections is highlighted on the Environmental Functions Screen, push the joystick to the right.

**NOTE: At any time a left command will return to the previous menu.**

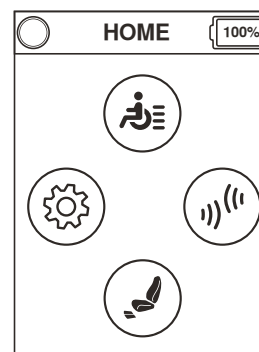

Home Screen

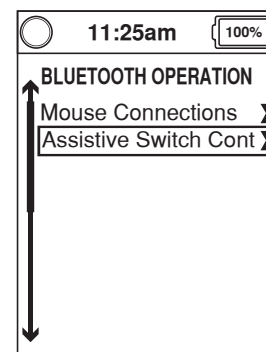

Bluetooth

After Assistive Switch Control Connections is highlighted, a right command will show.

**NOTE: Gray icons indicate unpaired Q-Logic 3; blue icons indicate paired Q-Logic 3.**

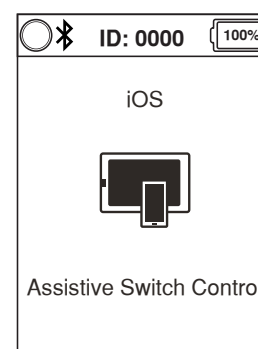
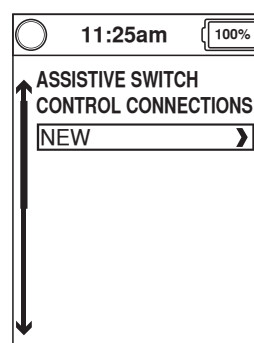

**NOTE: This product has been tested for Electromagnetic and Radio Frequency Interference (EMI/RFI) and has met standard requirements. Please refer to the Consumer Safety Guide for more information regarding EMI/RFI. Although we do not recommend using a cell phone while operating a power chair, the system is capable of receiving and/or making calls through a cell phone device, accessing music files or contact lists, and navigating a device menu.**

### Bluetooth Electronic Specifications

Bluetooth Output Power	10 mW
Operation Range	40 m LOS (Line of Sight)
Operating Temperature	-40° F to 185° F / -40°C to 85° C
Storage Temperature	-67° F to 302° F / -55°C to 150° C
RF Wireless Technology Type	Co-existence with IEEE 802.11 (AWMA, AFH)
Encryption Security	128-bit

### EMC Testing on Sample Wheelchair

Susceptibility	Tested to 20V/m to IEC 61000-4-3
Emissions	To CISPR11, Group 1, Class B
ESD	To IEC 61000-4-2



---

## Standby Select Menu

The Standby Select Menu screen appears after the programmed timeout when Standby Select is enabled. Standby Select will navigate the Home Screen allowing the user to access the drive, seat or settings screen, Contact your Quantum Rehab Provider for more information.

## Attendant Control and Standalone Joystick

For more information on these applications, contact your Quantum Rehab Provider.

The Attendant Control and the Stand-alone Joystick are similarly laid out:

- On/Off Button  
Enables/disables power
- Mode Button  
Cycle through Drive Profiles and Seat Mode (if equipped)
- Battery Condition Meter  
Indicates battery charge
- Actuator LEDs  
Indicates actuators in use
- Mode LED  
Used for profile selection
- Joystick  
They joystick controls speed and direction in Drive mode. Push the joystick to the right to select actuators in Seat mode. Move the joystick forward or backward to activate the desired actuator(s).
- On/Off and Mode Jacks  
Allow for remote On/Off and Mode switch installations

## Enhanced Display

The Enhanced Display module is primarily used with specialty control devices such as a head array. It also can be used to provide a graphic display for the Stand-alone Joystick. When used with the hand control, it provides a larger display than the hand control's LCD. The Enhanced Display is mainly used in more advanced applications. Contact your Quantum Rehab Provider for more information.

The Enhanced Display has the following controls:

- On/Off Button  
Enables/disables power
- On/Off and Mode Jacks  
Allow for remote On/Off and Mode Switch installations
- Mode Button  
Allows changes to client modes without using the client's switch or input device
- 9-pin D-sub Connector  
Allows for connection of a specialty control device
- LCD Screen  
A color LCD display that may be equipped with built-in infrared (IR) for remote control and with Bluetooth mouse control
- 4-Direction Navigation Key  
The up/down arrows of the four-direction navigation key activate seating functions while the left/right arrows select previous (left) or next (right) seating functions (multiple seating functions required). The up/down arrows also navigate up and down through the menu on the setting/Aux screens and the left/right arrows function as Esc command (left) and Select (right).

### Enhanced Display settings

When the enhanced display is the active input device, cycling through the mode will reveal an Auxiliary screen, after the drive screens and before the seat screen.

The Auxiliary screen gives the user access to the settings. The settings in the Enhanced Display are the same as the setting found under the "Home Button Section" of this manual. All adjustments are performed the same way

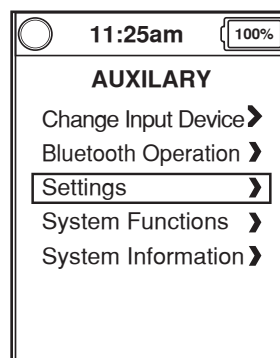

**AUXILIARY**

## Sleep Mode

The Q-Logic 3 Controller offers a sleep mode feature that will shut off the main power if the joystick remains stationary for a programmed period of time from 0 to 240 minutes. To restore power and resume operation of the chair, push the On/Off and Mode Select Lever up once. A set time of 0 minutes disables the sleep mode feature.

## Thermal Rollback

The Q-Logic 3 Controller is equipped with a thermal rollback circuit that monitors the temperature of the chair's motors and controller. If either exceeds the safe operating temperature, the controller reduces the output to 20% of full operation level. This reduces the chair's speed and allows a cool-down period. Once the temperature returns to a safe level, the chair will resume normal operation.

## Battery Condition Meter

The battery condition meter is located in front of the joystick on the hand control and as an LED on the Attendant Control and Stand-alone Joystick.

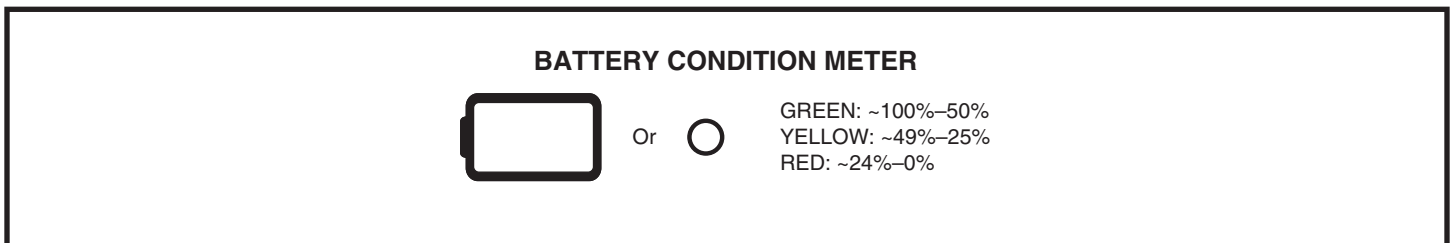

Figure 2. Battery Condition Meter

## Q-Logic 3 Error Codes

The Q-Logic 3 displays three types of messages: information, warning, and error. **See figure 3.**

- **Information:** Displays information that does not impact power chair functionality or performance.
- **Warning:** Alerts you to conditions that may affect power chair functionality and performance.
- **Error:** Alerts you to conditions that influence power chair functionality and performance.

Error codes are displayed on the LCD by number. The following table identifies the error codes that may be easily rectified, probably causes, and possible solutions. If you receive one of these error codes, follow the recommended solution, and if the problem persists, you receive any other error code or experience any other problem with your power chair, contact your Quantum Rehab Provider.

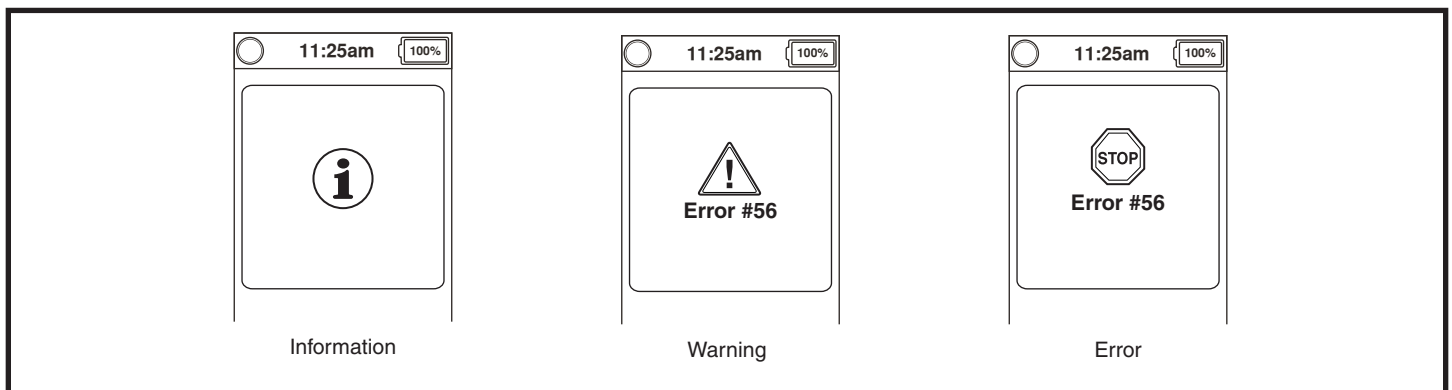

Figure 3. Error Codes

Error Code	Popup Text	Description (programming device)	Help text (programming device)
1	Motor 1 not connected	Error: Motor 1 not connected	Motor 1 error detected 1. Turn power off 2. Inspect motor connections 3. Turn power on
2	Motor 2 not connected	Defect: Motor 2 not connected	Motor 2 error detected 1. Turn power off 2. Inspect motor connections 3. Turn power on
3	Brake 1 not connected	Error: Brake 1 not connected	Brake 1 error detected 1. Turn power off 2. Disengage then re-engage brake lever 3. Inspect motor connections 4. Turn power off
4	Brake 2 not connected	Error: Brake 2 not connected	Brake 2 error detected 1. Turn power off 2. Disengage then re-engage brake lever 3. Inspect motor connections 4. Turn power off
20	Undervoltage	Error: Undervoltage	Charge Battery
21	Overvoltage	Error: Overvoltage	Check the battery voltage, batteries may be overcharged. Avoid driving downhill fast with fully charged batteries.
23	Motor 1 output defect	Error: Motor 1 output defect	Motor 1 error detected 1. Turn power off 2. Inspect motor connections 3. Turn power on
24	Motor 2 output defect	Error: Motor 2 output defect	Motor 2 error detected 1. Turn power off 2. Inspect motor connections 3. Turn power on
25	Brake 1 error	Error: Brake 1 error	Brake 1 error detected 1. Turn power off 2. Disengage then re-engage brake lever 3. Inspect motor connections 4. Turn power on
26	Brake 2 error	Error: Brake 2 error	Brake 2 error detected 1. Turn power off 2. Disengage then re-engage brake lever 3. Inspect motor connections 4. Turn power on
32	Speed reduction (Overtemperature)	Error: Speed reduction (Overtemperature)	Chair speed is reduced to protect system electronics 1. Turn power off to let system cool down. NOTE: This is the normal system behavior
34	Joystick not centered	Error: Joystick not centered	Joystick deflected at power up 1. Turn power off 2. Release joystick to neutral position 3. Turn power on
35	Joystick out of center	Defect: Joystick out of center	Joystick deflected at power up 1. Turn power off 2. Release joystick to neutral position 3. Turn power on

Error Code	Popup Text	Description (programming device)	Help text (programming device)
46	Bluetooth not working	Defect: Bluetooth not working	Bluetooth error detected. Please reboot system. 1. Turn power off. 2. Wait 5 seconds 3. Turn power on
47	Suspension lock not engaged - Seek level ground	Defect: Suspension lock not engaged - Seek level ground	Suspension lock not engaged 1. Seek level ground 2. Check suspension lock mechanism

### Care and Maintenance

Refer to your power chair owner's manual for proper cleaning and disposal instructions.

### Temperature

Some of the parts of your power chair are susceptible to extreme changes in temperature. Always keep your power chair between the temperatures of 18°F (-8°C) and 122°F (50°C).

### Warranty

Refer to your power chair owner's manual for specific information on controller warranty.







## **USA**

401 York Avenue  
Duryea, PA 18642

## **Canada**

5096 South Service Road  
Beamsville, Ontario L0R 1B3

## **UK**

32 Wedgwood Road  
Bicester, Oxfordshire OX26 4UL  
[www.quantumrehab.co.uk](http://www.quantumrehab.co.uk)

## **Australia**

20-24 Apollo Drive  
Hallam, Victoria 3803  
[www.quantumrehab.com.au](http://www.quantumrehab.com.au)

## **New Zealand**

38 Lansford Crescent  
Avondale  
Auckland, New Zealand 1007  
[www.pridemobility.co.nz](http://www.pridemobility.co.nz)

## **Italy**

Via del Progresso, ang. Via del Lavoro  
Loc. Prato della Corte  
00065 Fiano Romano (RM)  
[www.quantumrehab-italia.it](http://www.quantumrehab-italia.it)

## **B.V.**

Castricummer Werf 26  
1901 RW Castricum  
The Netherlands  
[www.quantumrehab.eu](http://www.quantumrehab.eu)

[www.quantumrehab.com](http://www.quantumrehab.com)

